

DIGITAL WORKSTATION

PSR-S550/PSR-S550B

SERVICE MANUAL



PSR-S550



PSR-S550B

■ CONTENTS (目次)

SPECIFICATIONS	3
PANEL LAYOUT	4
CIRCUIT BOARD LAYOUT & WIRING (ユニットレイアウト及び結線図)	6
EXTENSION CABLE FOR SERVICE USE (サービス用延長ケーブル)	7
BLOCK DIAGRAM (ブロックダイアグラム)	8
DISASSEMBLY PROCEDURE (分解手順)	9
LSI PIN DESCRIPTION (LSI 端子機能表)	16
IC BLOCK DIAGRAM (IC ブロック図)	20
CIRCUIT BOARDS (シート基板図)	21
TEST PROGRAM	33
INITIALIZATION	37
DATA BACKUP	38
SYSTEM BOOTING FLOW CHART	43
MIDI IMPLEMENTATION CHART (MIDI インプリメンテーションチャート)	44
MIDI DATA FORMAT	45
PARTS LIST	
OVERALL CIRCUIT DIAGRAM (総回路図)	

IMPORTANT NOTICE

This manual has been provided for the use of authorized Yamaha Retailers and their service personnel. It has been assumed that basic service procedures inherent to the industry, and more specifically Yamaha Products, are already known and understood by the users, and have therefore not been restated.

WARNING: Failure to follow appropriate service and safety procedures when servicing this product may result in personal injury, destruction of expensive components and failure of the product to perform as specified. For these reasons, we advise all Yamaha product owners that all service required should be performed by an authorized Yamaha Retailer or the appointed service representative.

IMPORTANT: This presentation or sale of this manual to any individual or firm does not constitute authorization certification, recognition of any applicable technical capabilities, or establish a principal-agent relationship of any form.

The data provided is believed to be accurate and applicable to the unit(s) indicated on the cover. The research engineering, and service departments of Yamaha are continually striving to improve Yamaha products. Modifications are, therefore, inevitable and changes in specification are subject to change without notice or obligation to retrofit. Should any discrepancy appear to exist, please contact the distributor's Service Division.

WARNING: Static discharges can destroy expensive components. Discharge any static electricity your body may have accumulated by grounding yourself to the ground bus in the unit (heavy gauge black wires connect to this bus.)

IMPORTANT: Turn the unit OFF during disassembly and parts replacement. Recheck all work before you apply power to the unit.

WARNING: This product contains chemicals known to the State of California to cause cancer, or birth defects or other reproductive harm.

DO NOT PLACE SOLDER, ELECTRICAL/ELECTRONIC OR PLASTIC COMPONENTS IN YOUR MOUTH FOR ANY REASON WHAT SO EVER!

Avoid prolonged, unprotected contact between solder and your skin! When soldering, do not inhale solder fumes or expose eyes to solder/ flux vapor!

If you come in contact with solder or components located inside the enclosure of this product, wash your hands before handling food.

■ WARNING

Components having special characteristics are marked  and must be replaced with parts having specification equal to those originally installed.

■ SAVING DATA

Saving and backing up your data



Be sure to perform it

The panel settings and some other types of data are not retained in memory when you turn off the power to the instrument. Save data you want to keep to the Registration Memory.

Saved data may be lost due to malfunction or incorrect operation.

Save important data to a USB storage device/or other external device such as a computer.

Backing up the USB storage device/external media



Be sure to perform it

To protect against data loss through media damage, we recommend that you save your important data onto two USB storage devices/external media.

■ SPECIFICATIONS

Keyboards

- 61 Standard-size keys (C1–C6), with Touch Response.

Display

- 320 x 240 dots LCD display (backlit)

Setup

- STANDBY/ON
- MASTER VOLUME: MIN–MAX
- LCD CONTRAST

Panel Controls

- DEMO, SONG MODE
- SONG-PRESET, SONG-USER, SONG-SCORE, SONG-LYRICS, SONG-REC
- USB
- STYLE CATEGORY, VOICE CATEGORY
- TRANSPOSE [-] [+], METRONOME, TAP TEMPO, TEMPO [-] [+]
- OTS LINK, AUTO FILL IN, ACMP, INTRO [1]–[3], MAIN VARIATION [A]–[D], ENDING/rit. [1]–[3] (REW) (FF), SYNC STOP (A-B REPEAT), SYNC START (PAUSE), START/STOP
- REGIST/PART [MIXER], MEMORY, REGIST BANK [-] [+], REGISTRATION MEMORY [1]–[8], STYLE [1]–[8], SONG [1/9]–[8/16], EXIT, CATEGORY [◀] [▶], Dial, [+ / YES] [- / NO]
- EXECUTE, MDB, FILE MENU, FUNCTION, ONE TOUCH SETTING [1]–[4], LEFT, DUAL, HARMONY, TOUCH, SUSTAIN, DSP, UPPER OCTAVE [-] [+]

Realtime Control

- Pitch Bend Wheel

Voice

- 294 Voices + 12 Drum Kits + 10 SFX Kits + 480 XG Voices (Included 11 Regional Voices and 8 Regional Drum/Percussion Kits)
- Polyphony: 64
- LEFT
- DUAL

Style

- 176
- Style Control: ACMP ON/OFF, SYNC STOP, SYNC START, START/STOP, INTRO [1]–[3], MAIN VARIATION [A]–[D], ENDING/rit. [1]–[3], AUTO FILL IN
- Style Creator
- Fingering: Multi Finger, Full Keyboard
- Style Volume

Music Database

- 600

Registration Memory

- 8 banks x 8 memories
- Regist Clear

Mixer

- Volume, Pan, Reverb, Chorus

Function

- VOLUME: Style Volume, Song Volume
- OVERALL: Tuning, Pitch Bend Range, Split Point, Touch Sensitivity, Chord Fingering
- MAIN VOICE: Volume, Octave, Pan, Reverb Level, Chorus Level, DSP Level, Dry Level
- DUAL VOICE: Volume, Octave, Pan, Reverb Level, Chorus Level, DSP Level, Dry Level
- LEFT VOICE: Volume, Octave, Pan, Reverb Level, Chorus Level, DSP Level, Dry Level
- EFFECT: Reverb Type, Chorus Type, DSP Type, Master EQ Type
- HARMONY: Harmony Type, Harmony Volume
- PC: PC Mode
- MIDI: Local On/Off, External Clock, Keyboard Out, Style Out, Song Out, Initial Setup
- METRONOME: Time Signature Numerator, Time Signature Denominator, Bell On/Off, Metronome Volume
- SCORE: Quantize, Right-Part, Left-Part
- UTILITY: Demo Cancel, TG Mode
- LANGUAGE: Language

Effects

- Harmony: 26 types
- Reverb: 35 types
- Chorus: 44 types
- DSP: 237 types

Song

- 5 Preset Songs + User Songs + USB Memory
- Song Clear, Track Clear
- Song Volume
- Song Control: A-B REPEAT, PAUSE, REW, FF, START/STOP

Recording

- Song
 - User Song: 5 Songs
 - Recording Tracks: 1–16, STYLE
- Style Creator

MIDI

- Local On/Off
- Initial Setup
- External Clock
- Keyboard Out
- Style Out
- Song Out

Auxiliary jacks

- PHONES/OUTPUT, DC IN 16V, USB TO HOST, USB TO DEVICE, SUSTAIN

Amplifier

- 12W x 2

Speakers

- (12cm + 3cm) x 2

Power Consumption

- 25W

Power Supply

- Adaptor: Yamaha PA-301 or PA-300 AC power adaptor

Dimensions (W x D x H)

- 946 x 402 x 130 mm (37-1/4" x 15-7/8" x 5-1/8")

Weight

- 7.5kg (16 lbs., 9 oz.)

Supplied Accessories

- Music Rest
- Accessory CD-ROM
- Owner's Manual
- AC Power adaptor (May not be included depending on your particular area.)

Optional Accessories

- Headphones: HPE-150
- Keyboard Stand: L6
- Foot Switch: FC4/FC5

■ PANEL LAYOUT

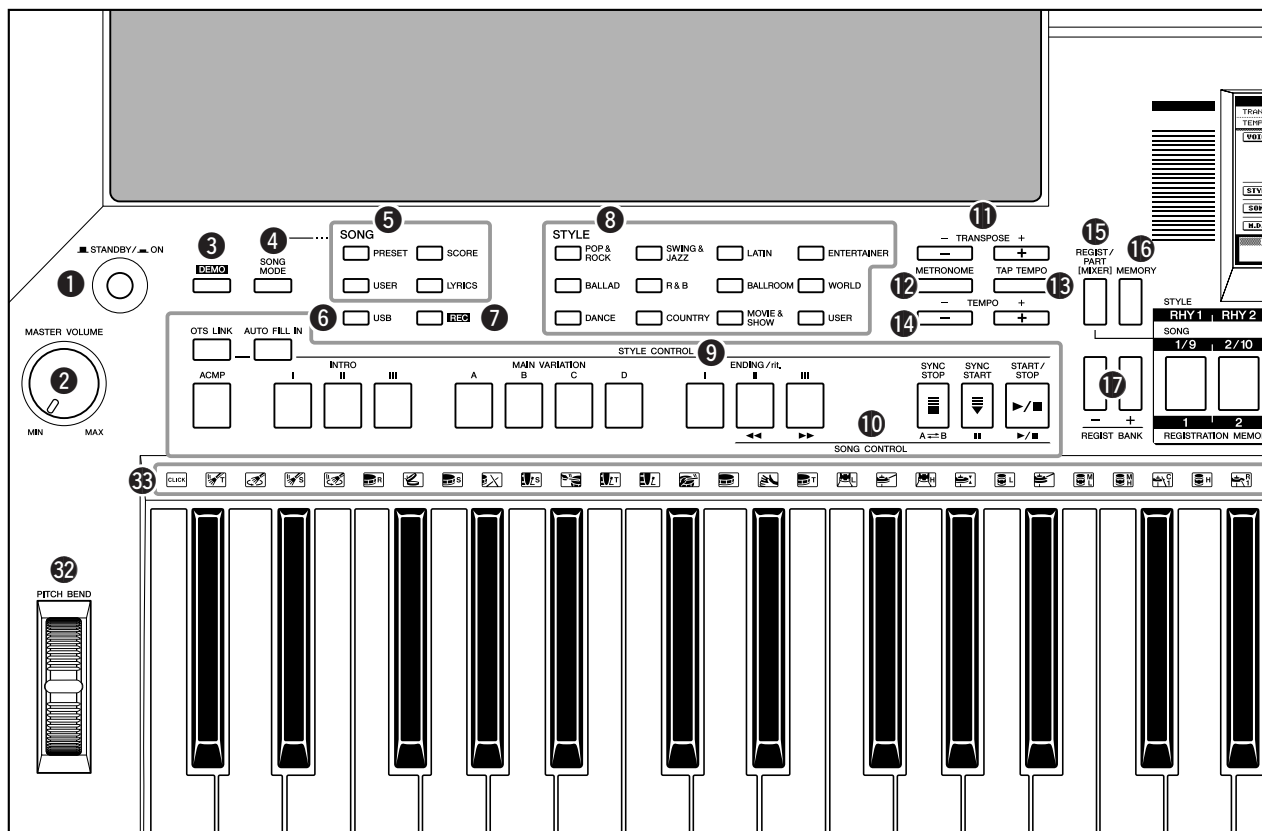

• Front Panel

- ① [STANDBY/ON] switch
- ② [MASTER VOLUME] control
- ③ [DEMO] button
- ④ [SONG MODE] button
- ⑤ SONG
[PRESET], [USER], [SCOPE]
[LYRICS] buttons
- ⑥ [USB] button
- ⑦ [REC] button
- ⑧ STYLE
- ⑨ STYLE CONTROL
[OTS LINK], [AUTO FILL IN], [ACMP]
INTRO [I]-[III], MAIN VARIATION [A]-[D]
ENDING/rit. [I]-[III], [SYNC STOP]
[SYNC START], [START/STOP] buttons
- ⑩ SONG CONTROL
[<<], [>>], [A ⇌ B], [|||], [▶/■] buttons
- ⑪ TRANSPOSE [+] and [-] buttons
- ⑫ [METRONOME] button
- ⑬ [TAP TEMPO] button
- ⑭ TEMPO [+] and [-] buttons
- ⑮ [REGIST/PART[MIXER]] button
- ⑯ [MEMORY] button
- ⑰ REGIST BANK [+] and [-] buttons
- ⑱ Style Part/Song Part [1/9]-[8/16]/
REGISTRATION MEMORY [1] - [8] buttons
- ⑲ DISPLAY
- ⑳ [EXIT] button

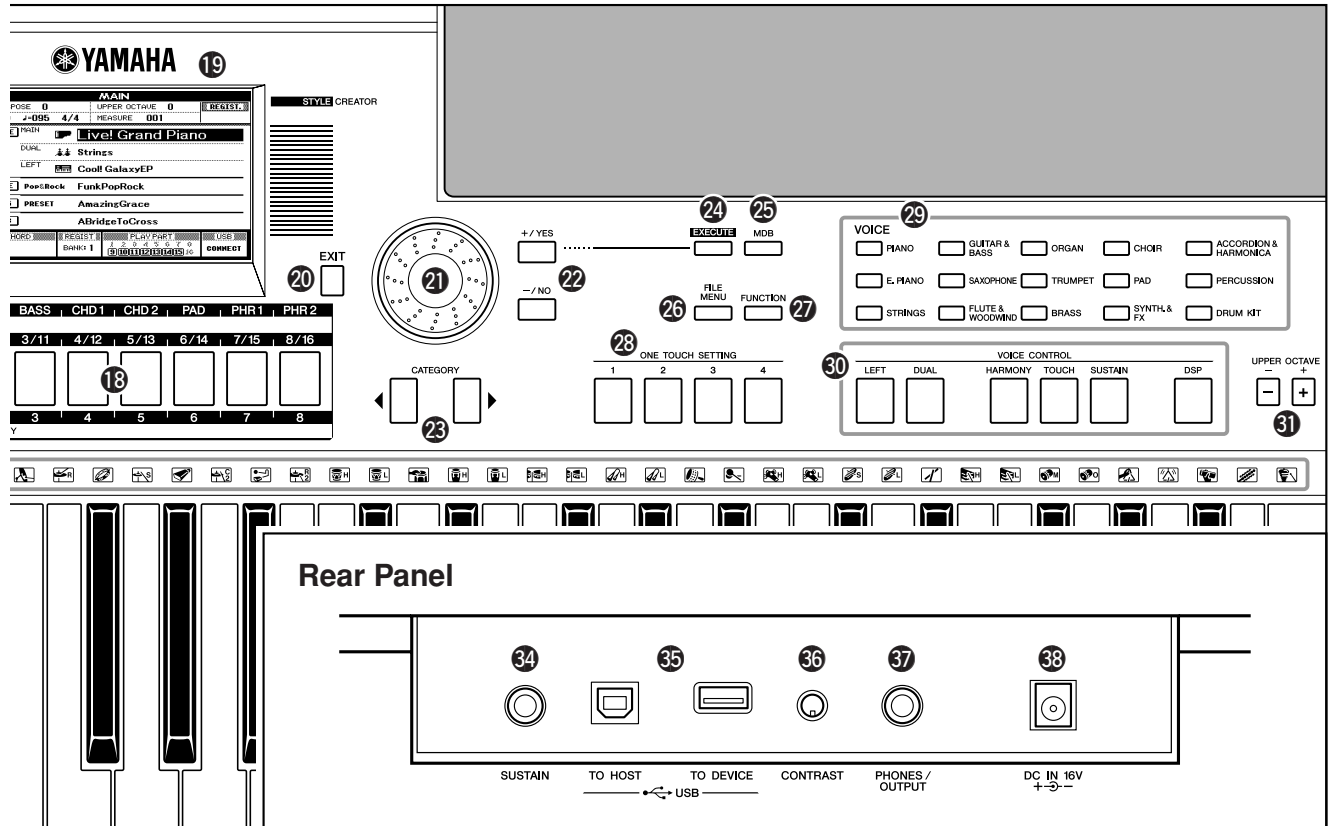

- 21 Dial
- 22 [+ / YES] and [- / NO] buttons
- 23 CATEGORY [◀] and [▶] buttons
- 24 [EXECUTE] button
- 25 [MDB] button
- 26 [FILE MENU] button
- 27 [FUNCTION] button
- 28 ONE TOUCH SETTING [1] - [4] buttons
- 29 VOICE
- 30 VOICE CONTROL
[LEFT], [DUAL], [HARMONY], [TOUCH]
[SUSTAIN], [DSP] buttons
- 31 UPPER OCTAVE [+] and [-] buttons
- 32 [PITCH BEND] wheel
- 33 Drum Kit

• Rear Panel

- 34 SUSTAIN jack
- 35 USB TO HOST and TO DEVICE terminals
- 36 CONTRAST knob
- 37 PHONES/OUTPUT jack
- 38 DC IN 16V jack

■ CIRCUIT BOARD LAYOUT & WIRING(ユニットレイアウト及び結線図)

• Upper Case Assembly (上ケース Ass'y)

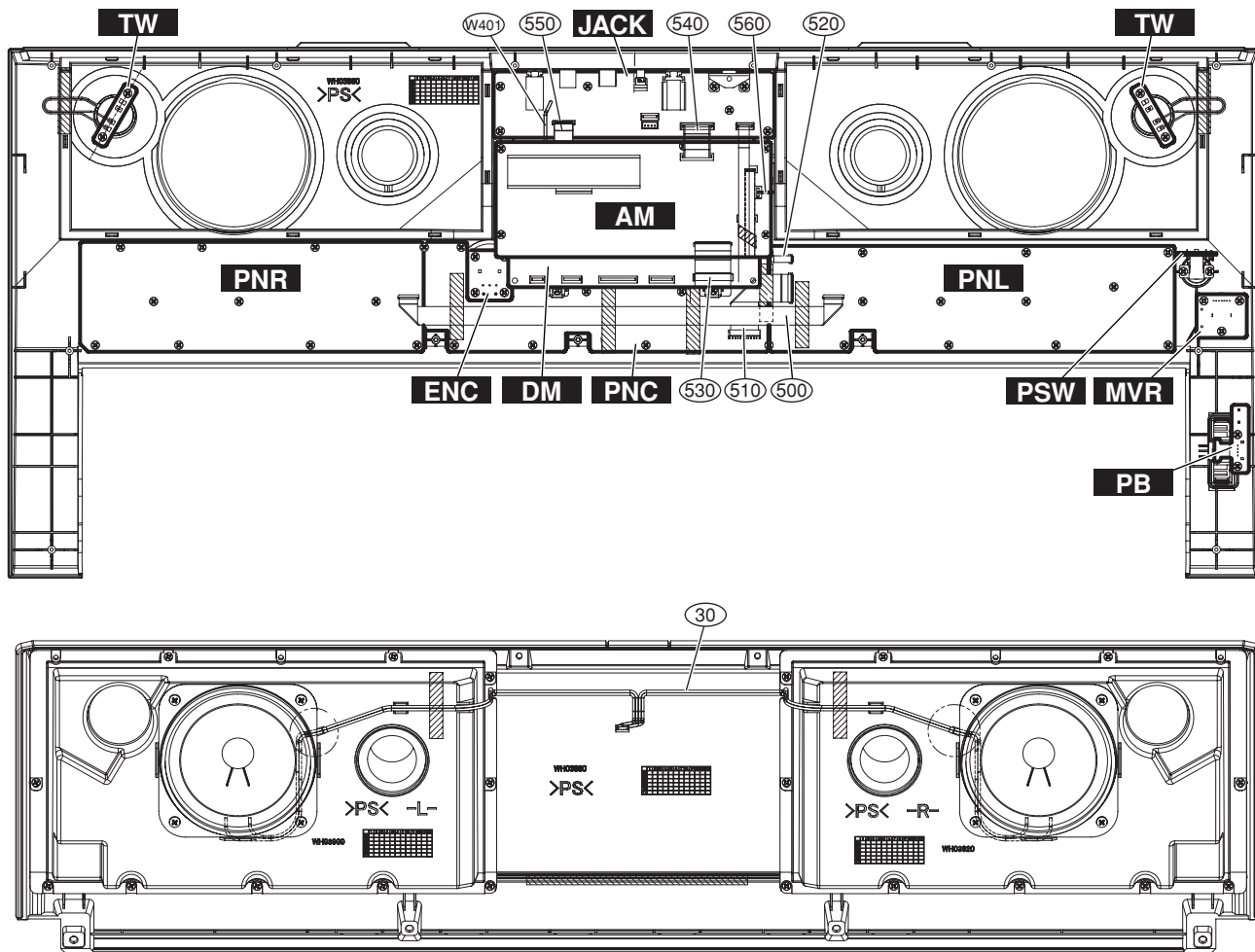

• Lower Key Bed Assembly (下ケース鍵盤 Ass'y)

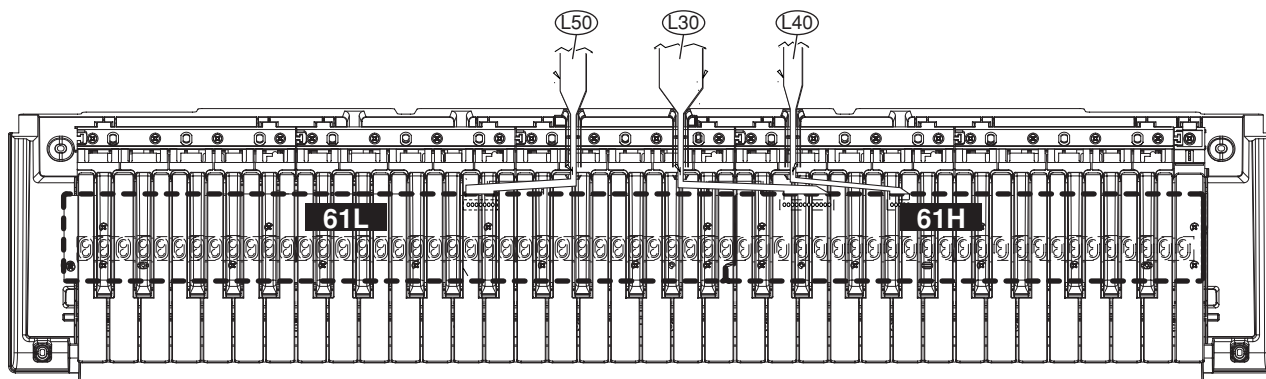

No.	Ref. No.	Part No. (パーツNo.)	Assembly (束線)	Destination (行き先)		Remarks (備考)
1	30	(WH33630)*1	SP	JACK-CN453	SP(WF)	4P
2	500	WJ465900	FFC4	PNL-CN102*2	PNR-CN301*2	14P
3	510	WJ466000	FFC5	PNC-CN202*2	PNL-CN101*2	21P
4	520	WQ075900	FFC2	DM-CN701*2	PNL-CN103*2	7P
5	530	WJ465800	FFC3	DM-CN901*2	AM-CN104*2	27P
6	540	(WJ46010)*1	JKAM	AM-CN101	JACK-CN451	10P
7	550	WJ465600	FFC1	DM-CN501*2	JACK-CN403*2	14P
8	560	WH336400	LCD	AM-CN102	LCD	2P
9	L30	WE13850R	MK1	DM-CN801	61H-CN1	12P L=220
10	L40	WE13870R	MK2	DM-CN803	61H-CN2	5P L=250
11	L50	WE13880R	MK3	DM-CN802	61L-CN5	7P L=190
12	W401	(WJ45910)*1	GND	JACK(Soldered)	FG	L=70

*1: The parts with "(" in "Part No." are not available as service parts.

*1: 上記束線のうち、部品No.に "(" がついている部品は、サービス部品として準備されていません。

*2: Edge mark is adjusted to pin 1 mark(Δ mark).

*2: エッジマークを1ピン側(Δマーク)に合わせます。

■ EXTENSION CABLE FOR SERVICE USE (サービス用延長ケーブル)

Check the AM circuit board and the DM circuit board by using the following extension cables.

(AMシートやDMシートは、下記の延長ケーブルを使うとチェックが容易になります。)

- JK-AM extension cable (JK-AMシート間の延長ケーブル)
V8973600 JUMPER WIRE FVP=2.0C26SB10-400 (ジャンパーワイヤー FVP=2.0C26SB10-400)
- AM-DM extension cable (AM-DMシート間の延長ケーブル)
WG123900 FFC CABLE P-70 (FFCケーブル P-70)

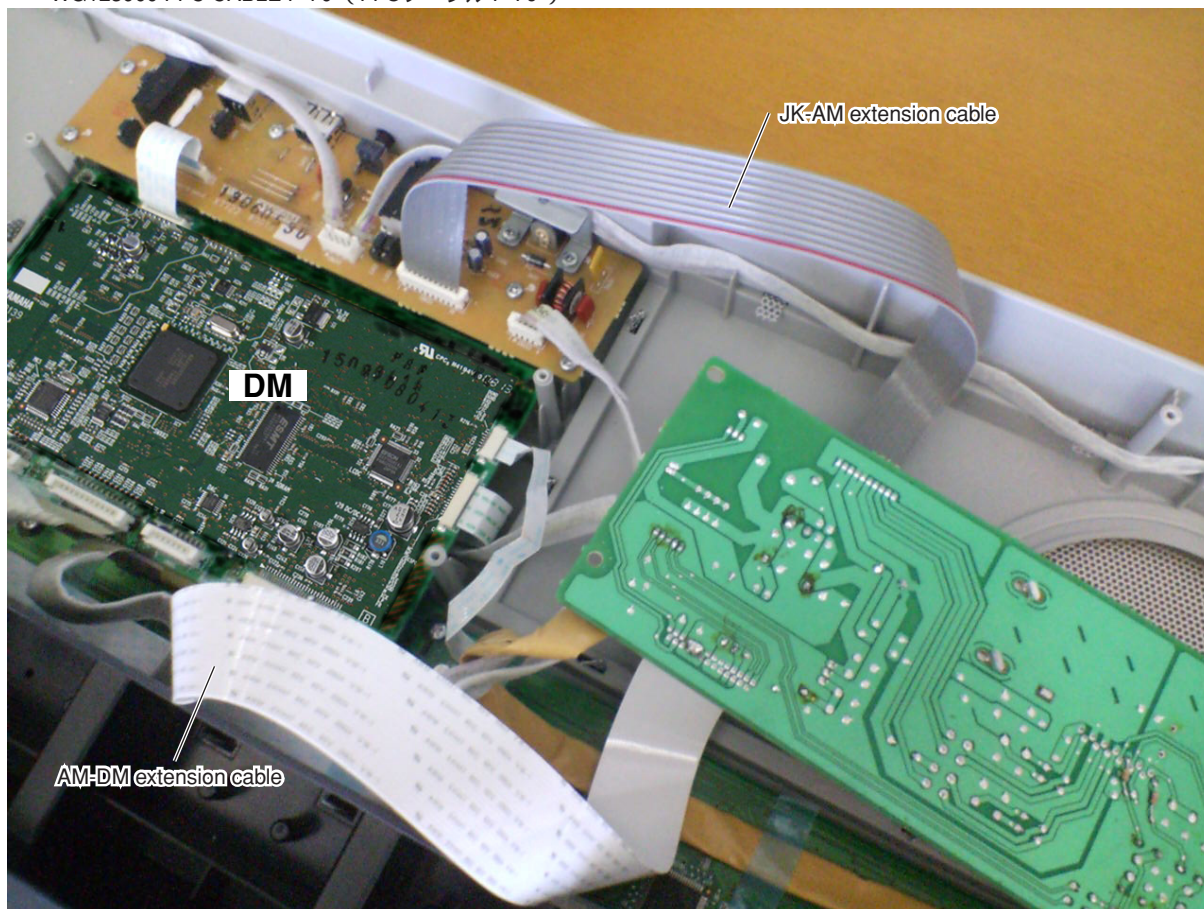

BLOCK DIAGRAM (フロツクダイアグラム)

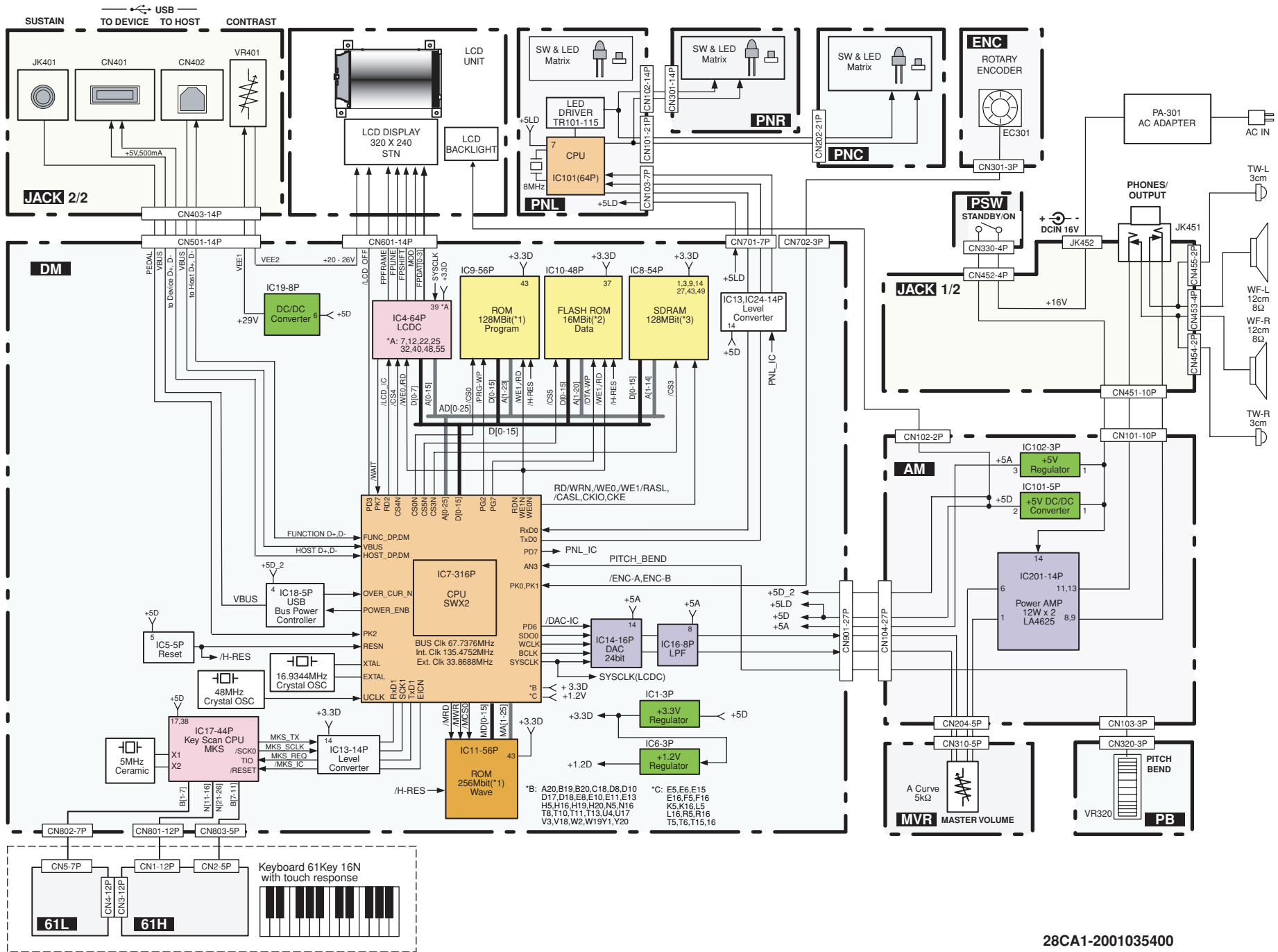

■ DISASSEMBLY PROCEDURE (分解手順)

CAUTION:

- Be sure to attach the removed filament tape just as it was before removal.
- Contacts are visible from the back. Pay attention not to insert and install the cable to the connector inversely. (Fig.1)

(注意) :

- 一度剥がしたフィラメントテープは、取り外す前と同じように、取り付けてください。
- フラットケーブルの接点が裏側から透けて見えます。コネクタにケーブルの表、裏を逆に差し込まないように注意して取り付けてください。(図1)



Front Side (Printed Side)
(表面 (印刷面))



Back Side
(裏面)

Fig.1 (図1)

1. Lower Case Assembly

(Time required: About 2 minutes)

- 1-1 Remove the six (6) screws marked [80A], the two (2) screws marked [100A] and the two (2) screws marked [90]. The lower case assembly can then be removed. (Fig.2)

1. 下ケースAss'y

(所要時間：約2分)

- 1-1 [80A]のネジ6本、[100A]のネジ2本、[90]のネジ2本を外し、下ケースAss'yを外します。(図2)

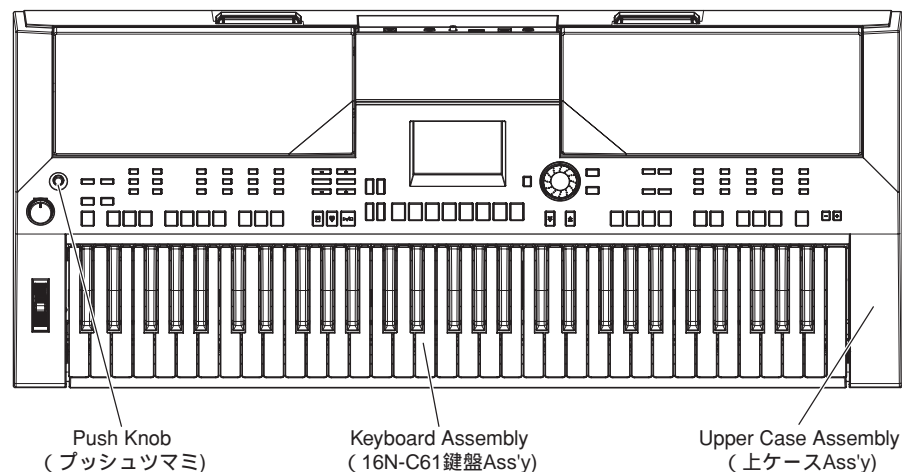
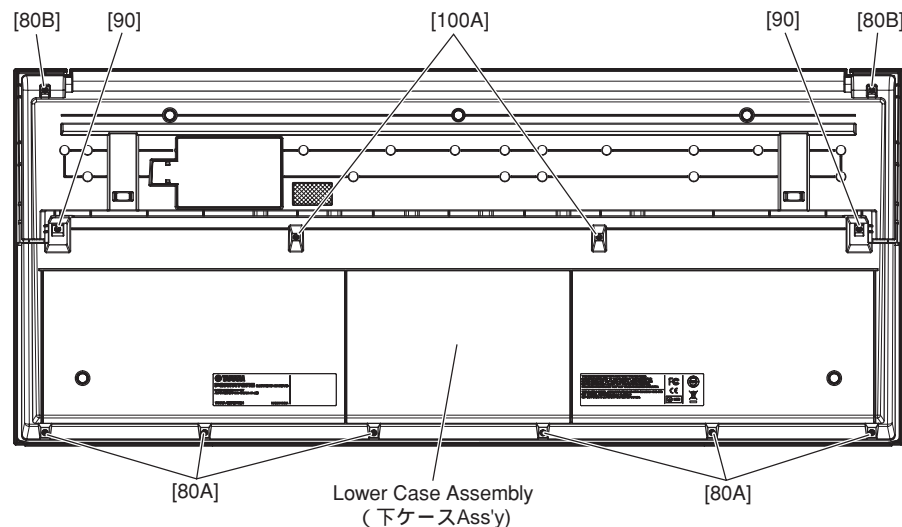

- [80]: Bind Head Tapping Screw-B 3.0X12 MFZN2W3 (WE98740R) B タイト + B I N D
 [90]: Bind Head Tapping Screw-B 3.0X20 MFZN2W3 (WF48930R) B タイト + B I N D
 [100A]: Bind Head Tapping Screw-B 3.0X30 MFZN2W3 (WF49100R) B タイト + B I N D

Fig.2 (図2)

**2. AM Circuit Board
(Time required: About 3 minutes)**

- 2-1 Remove the lower case assembly. (See procedure 1.)
- 2-2 Remove the five (5) screws marked [380B]. The AM circuit board can then be removed. (Fig.3)

**3. JACK Circuit Board
(Time required: About 3 minutes)**

- 3-1 Remove the lower case assembly. (See procedure 1.)
- 3-2 Remove the AM circuit board. (See procedure 2.)
- 3-3 Remove the screw marked [380E] at the location of "A". (Fig.4)
- * As for the screw marked [380E] at the location of "A", it is tightened together with a GND terminal. (Fig.4)
- 3-4 Remove the five (5) screws marked [380A] and the two (2) screws marked [385]. The JACK circuit board can then be removed. (Fig.3)

**2. AMシート
(所要時間：約3分)**

- 2-1 下ケースAss'yを外します。(1項参照)
- 2-2 [380B]のネジ5本を外し、AMシートを外します。(図3)

**3. JACKシート
(所要時間：約3分)**

- 3-1 下ケースAss'yを外します。(1項参照)
- 3-2 AMシートを外します。(2項参照)
- 3-3 "A"の位置の[380E]のネジ1本を外します。(図4)
- * "A"の位置の[380E]のネジはGND端子と共締めされています。(図4)
- 3-4 [380A]のネジ5本と[385]のネジ2本を外し、JACKシートを外します。(図3)

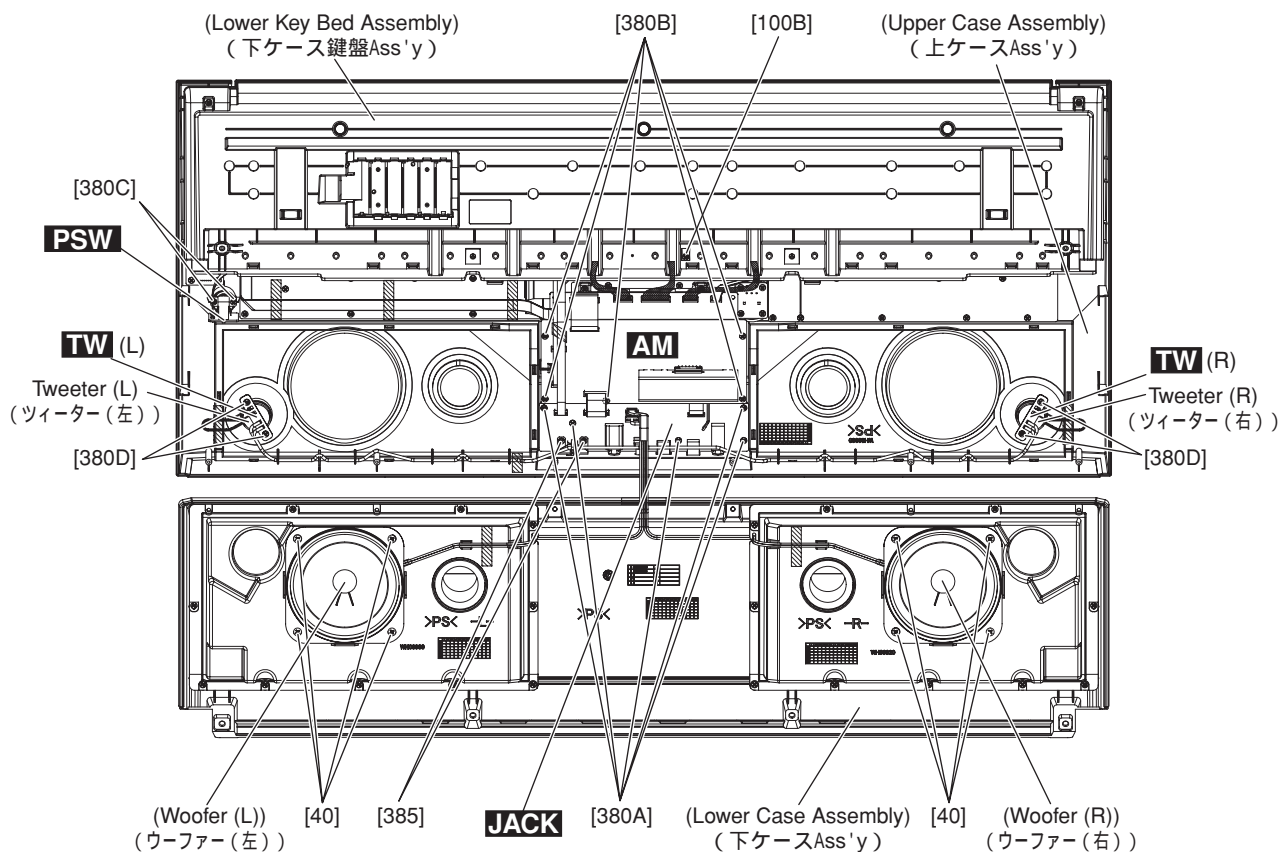

- [40]: Bind Head Tapping Screw-B 4.0X12 MFZN2W3 (WE98120R) B タイト + B I N D
- [100B]: Bind Head Tapping Screw-B 3.0X30 MFZN2W3 (WF49100R) B タイト + B I N D
- [380]: Bind Head Tapping Screw-B 3.0X8 MFZN2W3 (WE774301) B タイト + B I N D
- [385]: Bind Head Tapping Screw-B 3.0X12 MFZN2W3 (WE98740R) B タイト + B I N D

Fig.3 (図3)

**4. DM Circuit Board
(Time required: About 4 minutes)**

- 4-1 Remove the lower case assembly. (See procedure 1.)
- 4-2 Remove the AM circuit board. (See procedure 2.)
- 4-3 Remove the four (4) screws marked [380E]. The DM circuit board can then be removed. (Fig.4)
- * As for the screw marked [380E] at the location of "A", it is tightened together with a GND terminal. (Fig.4)

**4. DMシート
(所要時間：約4分)**

- 4-1 下ケースAss'yを外します。(1項参照)
- 4-2 AMシートを外します。(2項参照)
- 4-3 [380E]のネジ4本を外し、DMシートを外します。(図4)
- * "A"の位置の[380E]のネジ1本はGND端子と共締めされています。(図4)

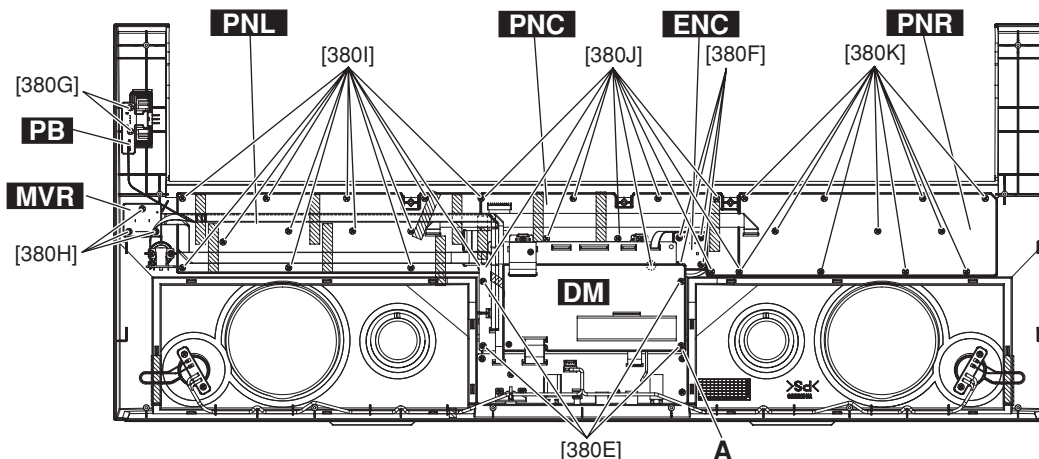

[380]: Bind Head Tapping Screw-B 3.0X8 MFZN2W3 (WE774301) Bタイト + B I N D

Fig.4 (図 4)

**5. LCD Unit
(Time required: About 5 minutes)**

- 5-1 Remove the lower case assembly. (See procedure 1.)
- 5-2 Remove the AM circuit board. (See procedure 2.)
- 5-3 Remove the DM circuit board. (See procedure 4.)
- 5-4 Remove the four (4) screws marked [380L]. The LCD unit can then be removed. (Fig. 5)

**5. 液晶ユニット
(所要時間：約5分)**

- 5-1 下ケースAss'yを外します。(1項参照)
- 5-2 AMシートを外します。(2項参照)
- 5-3 DMシートを外します。(4項参照)
- 5-4 [380L]のネジ4本を外し、液晶ユニットを外します。(図5)

**6. ENC Circuit Board
(Time required: About 4 minutes)**

- 6-1 Remove the lower case assembly. (See procedure 1.)
- 6-2 Remove the encoder knob from the control panel. (Fig. 6)
- 6-3 Remove the four (4) screws marked [380F]. The ENC circuit board can then be removed. (Fig.4)

**6. ENCシート
(所要時間：約4分)**

- 6-1 下ケースAss'yを外します。(1項参照)
- 6-2 コントロールパネル面からエンコーダツマミを外します。(図6)
- 6-3 [380F]のネジ4本を外し、ENCシートを外します。(図4)

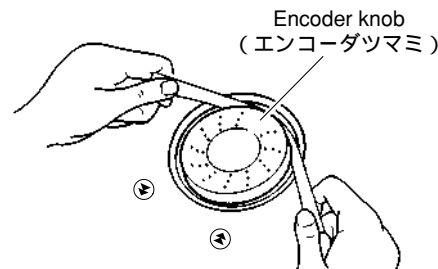
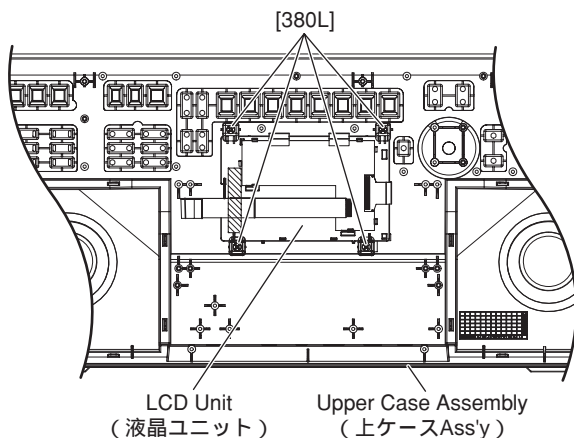

Fig.6 (図 6)

[380L]: Bind Head Tapping Screw-B 3.0X8 MFZN2W3 (WE774301) Bタイト + B I N D

Fig.5 (図 5)

7. PSW Circuit Board**(Time required: About 3 minutes)**

- 7-1 Remove the lower case assembly. (See procedure 1.)
- 7-2 Remove the two (2) screws marked [380C]. The PSW circuit board can then be removed. (Fig.3)
- 7-3 Pull out the push knob (black) from the PSW circuit board. (Fig.2)

8. TW Circuit Board, Speaker (Tweeter)**(Time required: About 3 minutes each)**

- 8-1 Remove the lower case assembly. (See procedure 1.)
- 8-2 Remove the two (2) screws marked [380D]. The speaker (tweeter) can then be removed. (Fig.3)
- * The tweeters L and R can be removed in the same manner.

9. Wheel Assembly, PB, MVR, PNL, PNC, PNR Circuit Boards

- 9-1 Remove the lower case assembly. (See procedure 1.)
- 9-2 Remove the two (2) screws marked [80B]. (Fig.2)
- 9-3 Remove the screw marked [100B]. The 16N keyboard assembly and the lower key bed assembly can then be removed. (Fig.3)

9-4 Wheel Assembly, PB Circuit Board**(Time required: About 4 minutes each)**

- 9-4-1 Remove the two (2) screws marked [380G]. The wheel assembly with the PB circuit board can then be removed.
- 9-4-2 Remove the PB circuit board from the wheel assembly. (Fig. 4)

9-5 MVR Circuit Board**(Time required: About 4 minutes)**

- 9-5-1 Remove the volume knob from the control panel. (Fig.7)
- 9-5-2 Remove the three (3) screws marked [380H]. The MVR circuit board can then be removed. (Fig.4)

9-6 PNL Circuit Board**(Time required: About 5 minutes)**

- 9-6-1 Remove the thirteen (13) screws marked [380I]. The PNL circuit board can then be removed. (Fig.4)

7. PSWシート**(所要時間：約3分)**

- 7-1 下ケースAss'yを外します。(1項参照)
- 7-2 [380C]のネジ2本を外し、PSWシートを外します。(図3)
- 7-3 PSWシートからプッシュツマミ(黒)を外します。(図2)

8. TWシート、スピーカ(ツイーター)**(所要時間：各約3分)**

- 8-1 下ケースAss'yを外します。(1項参照)
- 8-2 [380D]のネジ2本を外し、スピーカ(ツイーター)を外します。(図3)
- * 左右のツイーターは、それぞれ同じ方法で外すことができます。

9. ホイールAss'y、PB、MVR、PNL、PNC、PNRシート

- 9-1 下ケースAss'yを外します。(1項参照)
- 9-2 [80B]のネジ2本を外します。(図2)
- 9-3 [100B]のネジ1本を外し、16N鍵盤Ass'y、下ケース鍵盤Ass'yを外します。(図3)

9-4 ホイールAss'y、PBシート**(所要時間：約4分)**

- 9-4-1 [380G]のネジ2本を外し、ホイールAss'yと共にPBシートを外します。(図4)
- 9-4-2 ホイールAss'yから、PBシートを外します。(図4)

9-5 MVRシート**(所要時間：約4分)**

- 9-5-1 コントロールパネル面からボリュームツマミを外します。(図7)
- 9-5-2 [380H]のネジ3本を外し、MVRシートを外します。(図4)

9-6 PNLシート**(所要時間：約5分)**

- 9-6-1 [380I]のネジ13本を外し、PNLシートを外します。(図4)

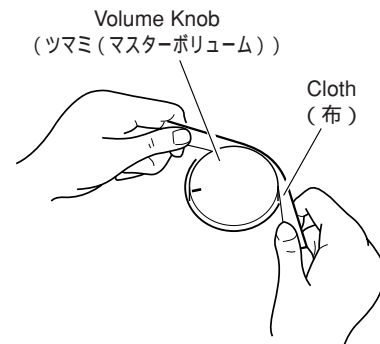

Fig.7 (図7)

9-7 PNC Circuit Board**(Time required: About 6 minutes)**

- 9-7-1 Remove the AM circuit board. (See procedure 2.)
- 9-7-2 Remove the DM circuit board. (See procedure 4.)
- 9-7-3 Remove the ten (10) screws marked [380J]. The PNC circuit board can then be removed. (Fig.4)

9-8 PNR Circuit Board**(Time required: About 5 minutes)**

- 9-8-1 Remove the eleven (11) screws marked [380K]. The PNR circuit board can then be removed. (Fig.4)

10. Speaker (Woofers)**(Time required: About 3 minutes each)**

- 10-1 Remove the lower case assembly. (See procedure 1.)
- 10-2 Remove the four (4) screws marked [40]. The speaker (woofer) can then be removed. (Fig.3)
- * The woofers L and R can be removed in the same manner.

11. Disassembling 16N Keyboard Assembly

- 11-1 Remove the lower case assembly. (See procedure 1.)
- 11-2 Remove the two (2) screws marked [80B]. (Fig.2)
- 11-3 Remove the screw marked [100B]. The 16N keyboard assembly and the lower key bed assembly can then be removed. (Fig.3)

11-4 White Keys and Black Keys

- 11-4-1 White and black keys for one octave unit are integrated as a set. There are five sets in total.
Only the C6 white key, unlike the other keys, is not integrated in a set. (Fig. 8)
- 11-4-2 To remove a set, remove the four (4) each screws marked [120A]. The white and black keys in the set can then be removed. (Fig. 8)
When removing, unfasten the two (2) hooks at the back of the black keys upward, and lift the white and black keys while pulling them toward you a little. (Fig.9)
- 11-4-3 To remove the white key C6, remove the screw marked [120B], unhook as described in Procedure 11-4-2, and pull out toward you. (Fig. 8)

11-5 Rubber Contact

- 11-5-1 Remove the white and black keys corresponding to the rubber contacts to be removed. (Fig.8, Photo.1)
- 11-5-2 Remove the rubber contacts. (Fig.8, Photo.1)

11-6 61L Circuit Board (MK-L)**(Time required: About 7 minutes)**

- 11-6-1 Remove the white and black keys from C1 to B3. (See Fig.8 and Procedure 11-4.)
- 11-6-2 Remove the four (4) screws marked [100A] and the eight (8) screws marked [110A]. The 61L circuit board (MK-L) can then be removed. (Fig.8)

9-7 PNCシート**(所要時間：約6分)**

- 9-7-1 AMシートを外します。(2項参照)
- 9-7-2 DMシートを外します。(4項参照)
- 9-7-3 [380J]のネジ10本を外し、PNCシートを外します。(図4)

9-8 PNRシート**(所要時間：約5分)**

- 9-8-1 [380K]のネジ11本を外し、PNRシートを外します。(図4)

10. スピーカ(ウーファー)**(所要時間：各約3分)**

- 10-1 下ケースAss'yを外します。(1項参照)
- 10-2 [40]のネジ4本を外し、スピーカ(ウーファー)を外します。(図3)
- * 左右のウーファーは、それぞれ同じ方法で外すことができます。

11. 16N鍵盤Ass'yの分解

- 11-1 下ケースAss'yを外します。(1項参照)
- 11-2 [80B]のネジ2本を外します。(図2)
- 11-3 [100B]のネジ1本を外し、16N鍵盤Ass'y、下ケース鍵盤Ass'yを外します。(図3)

11-4 白鍵、黒鍵

- 11-4-1 白鍵、黒鍵は、左側から1オクターブ単位のセットになっていて、全部で5セットあります。
C6鍵は、白鍵1個のみです。(図8)
- 11-4-2 セットのものは、[120A]のネジ4本ずつ外してそれぞれ1セット分の白鍵、黒鍵を外します。(図8)
この時、黒鍵の後ろ側にある2つのフックを上方向に外し、白鍵・黒鍵を少し手前に引きながら持ち上げます。(図9)
- 11-4-3 C6の白鍵は[120B]のネジ1本を外し、11-4-2項のようにフックを外して手前に引きながら外します。(図8)

11-5 接点ゴム

- 11-5-1 外そうとする接点ゴムに対応した白鍵・黒鍵を外します。(図8、写真1)
- 11-5-2 それぞれの接点ゴムを外します。(図8、写真1)

11-6 シート61L(MK-L)**(所要時間：約7分)**

- 11-6-1 C1～B3の白鍵・黒鍵を外します。(図8、11-4項参照)
- 11-6-2 [100A]のネジ4本と[110A]のネジ8本を外し、シート61L(MK-L)を外します。(図8)

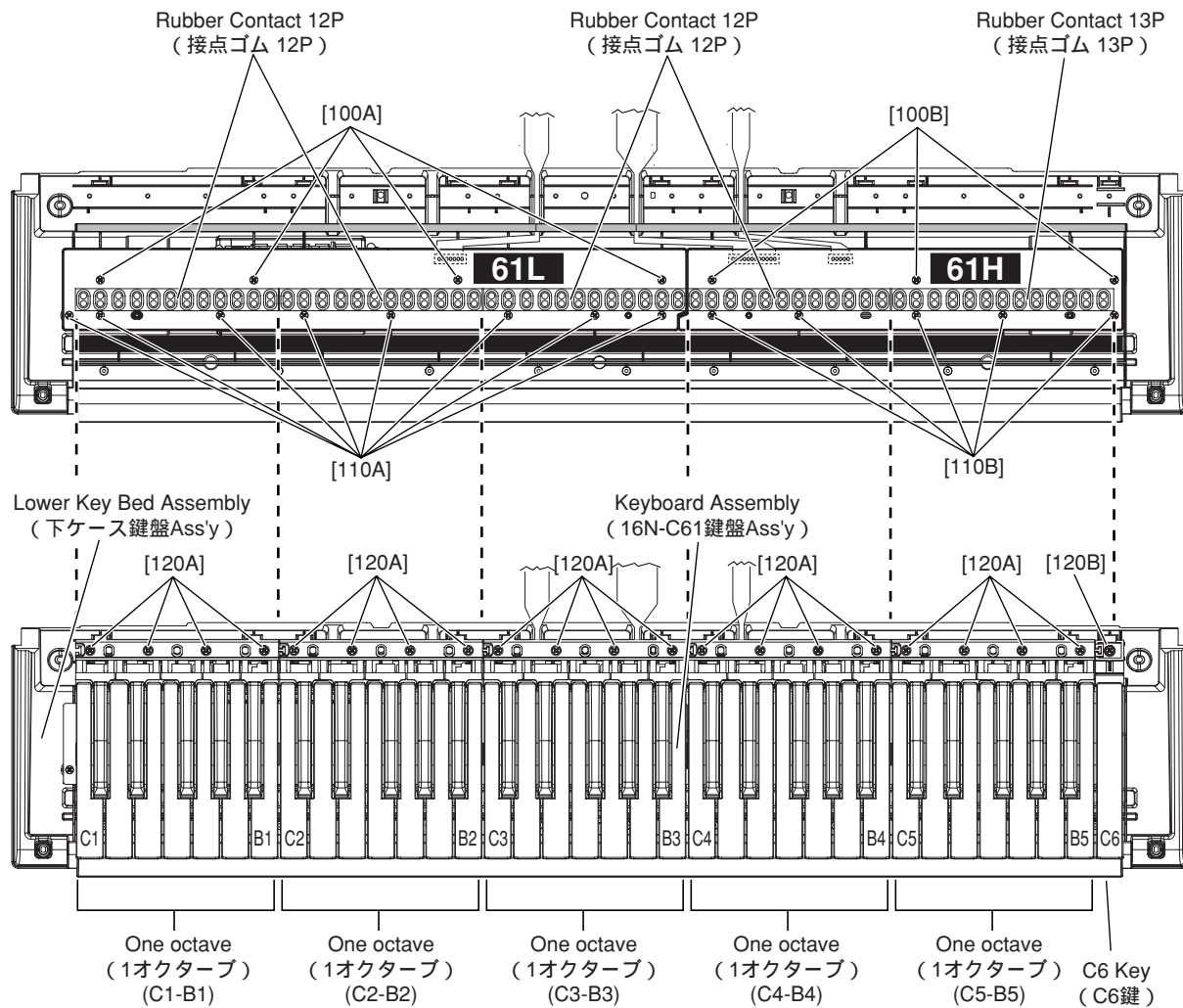

[100]: Bind Head Tapping Screw-B 3.0X8 MFZN2W3 (WE774301) B タイト + B I N D
 [110]: Bind Head Tapping Screw-P 3.0X12 MFZN2W3 SP (WH899400) P タイト + B I N D
 [120]: Bind Head Tapping Screw-P 3.0X20 MFZN2W3 (WF49200R) P タイト + B I N D

Fig.8 (図 8)

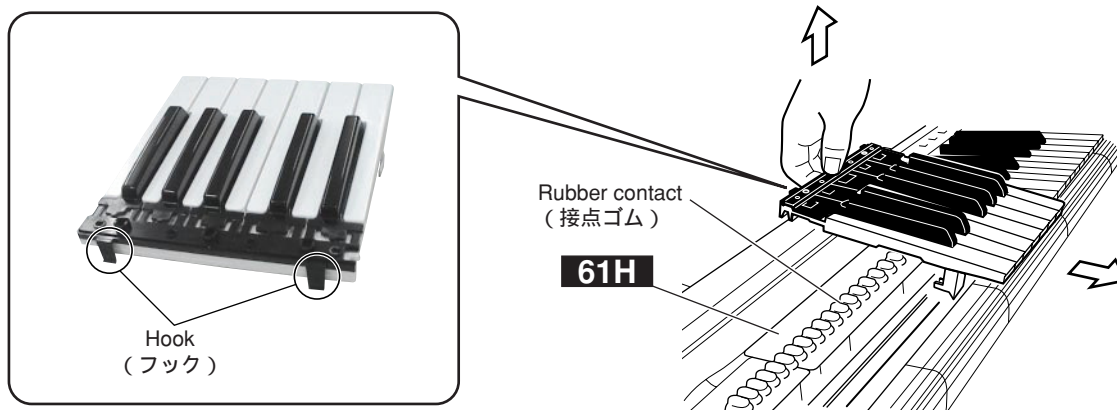

Fig.9 (図 9)

* When installing the 61L circuit board (MK-L), tighten the screws 1 through 12 in numerical order as shown in the figure "61L" in Fig.10. (Fig.10)

* シート61L(MK-L)を取り付ける時は、図10のシート61L図の番号1～12の順にネジを締めて下さい。(図10)

11-7 61H Circuit Board (MK-H)
(Time required: About 6 minutes)

11-7 シート61H(MK-H)
(所要時間：約6分)

11-7-1 Remove the white and black keys from C4 to C6. (See Fig.8 and Procedure 11-4.)

11-7-1 C4～C6の白鍵・黒鍵を外します。(図8、11-4項参照)

11-7-2 Remove the three (3) screws marked [100B] and the five (5) screws marked [110B]. The 61H circuit board (MK-H) can then be removed. (Fig.8)

11-7-2 [100B]のネジ3本と[110B]のネジ5本を外し、シート61H (MK-H)を外します。(図8)

* When installing the 61H circuit board (MK-H), tighten the screws 1 through 8 in numerical order as shown in the figure "61H" in Fig.10. (Fig. 10)

* シート61H(MK-H)を取り付ける時は、図10のシート61H図の番号1～8の順にネジを締めて下さい。(図10)

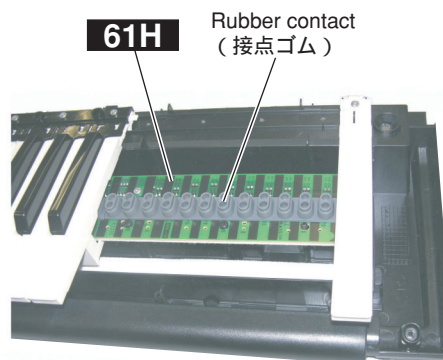

Photo.1 (写真 1)

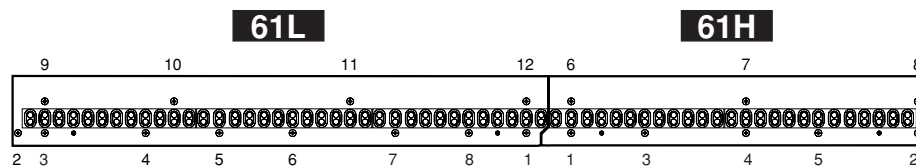

Fig.10 (図 10)

■ LSI PIN DESCRIPTION (LSI 端子機能表)

CONTENTS (目次)

- **AK4385ET (X6040A01) DAC** 16
- **MN101C027YB (XS71120R) CPU** 16
- **R8A0232BG (X8810A00) CPU (SWX02)** 17
- **S1D13700F01A100 (X5422A00) LCD CONTROLLER** 19
- **UPD789022GB-A15-8E (XZ56010R) CPU (MKS)** 19

● **AK4385ET (X6040A01) DAC (Digital to Analog Converter)**

DM: IC14

PIN NO.	NAME	I/O	FUNCTION	PIN NO.	NAME	I/O	FUNCTION
1	MCLK	I	Master Clock	9	AOUTR-	O	Rch Analog out(-)
2	BICK	I	Audio Serial Data Clock	10	AOUTR+	O	Rch Analog out(+)
3	SDTI	I	Audio Serial Date Input	11	AOUTL-	O	Lch Analog out(-)
4	LRCK	I	L/R Clock	12	AOUTL+	O	Lch Analog out(+)
5	PDN	I	Power Down mode	13	Vss	-	Ground
6	CSN	I	Chip Select	14	VDD	-	Power Supply
7	CCLK	I	Control Data Input	15	DZFR	O	Rch Data Zero Input Detect
8	CDTI	I	Control Data Input	16	DZFL	O	Lch Data Zero Input Detect

● **MN101C027YB (XS71120R) CPU**

PNL:IC101

PIN NO.	NAME	I/O	FUNCTION	PIN NO.	NAME	I/O	FUNCTION	
1	S1	I	} Switch matrix data	33	S12	I	} Switch matrix data	
2	S2	I		34	S13	I		
3	S3	I		35	S14	I		
4	S4	I		36	TXD	O		MIDI transmit data
5	S5	I		37	S15	I		} Switch matrix data
6	VREF+	-	38	S16	I			
7	VDD	-	39	S17	I			
8	OSC2	O	Power supply (+5V, analog)	40	S18	I	} Switch matrix data	
9	OSC1	I	Power supply (+5V)	41	L16	O		
10	VSS	-	Crystal oscillator (8MHz)	42	L17	O		
11	XI	I	Crystal oscillator (8MHz)	43	L18	O		
12	XO	O	Ground	44	L19	O		
13	MMOD	I	Not used	45	L8	O	} LED drive data	
14	RD0	O	Not used	46	L9	O		
15	RXD	I	Memory mode select (Grounded)	47	L10	O		
16	D0	O	Rotary encoder data	48	L11	O		
17	D1	O	MIDI receive data	49	L12	O		
18	D2	O	} LED and switch drive data	50	L13	O	} LED and switch drive data	
19	D3	O		21	/RST	I		
20	D4	O		22	D5	O		
21	/RST	I		Reset	23	D6		O
22	D5	O	} LED and switch drive data	24	D7	O		
23	D6	O		25	D8	O		
24	D7	O		26	D9	O		
25	D8	O		27	S6	I	} Switch matrix data	
26	D9	O	28	S7	I			
27	S6	I	29	S8	I			
28	S7	I	30	S9	I			
29	S8	I	31	S10	I			
30	S9	I	} Switch matrix data	32	S11	I		
31	S10	I		61	VREF	-	Grounded	
32	S11	I		62	AD0	I	Analog input	
				63	AD1	I	Analog input	
				64	S0	I	Switch matrix data	

● R8A02032BG (X8810A00) CPU (SWX02)

DM: IC7

PIN NO.	OUTER NO.	NAME	I/O	FUNCTION	PIN NO.	OUTER NO.	NAME	I/O	FUNCTION
1	A1	VSS	-	Ground	80	D20	VSSPLL	-	PLL analog ground
2	A2	AN2	I	ADC analog input 2	81	E1	MD6	I/O	Wave memory data bus 6
3	A3	AN1	I	ADC analog input 1	82	E2	MD7	I/O	Wave memory data bus 7
4	A4	VSS	-	Ground	83	E3	MD8	I/O	Wave memory data bus 8
5	A5	RxD1	I	Serial input 1	84	E4	MD9	I/O	Wave memory data bus 9
6	A6	SCK1	I	External sync. clock input 1	85	E5	VDD	-	Power supply +1.2 V
7	A7	UCLK	I	USB external clock input (48 MHz)	86	E6	VDD	-	
8	A8	VSS	-	Ground	87	E7	VSS	-	Ground
9	A9	FUNC_DM	I/O	USB function data -	88	E8	VCCQ	-	Power supply +3.3 V
10	A10	VSS	-	Ground	89	E9	VSS	-	Ground
11	A11	HOST_DM	I/O	USB host data -	90	E10	VCCQ	-	Power supply +3.3 V
12	A12	POWER_ENB	O	USB voltage enable	91	E11	VCCQ	-	
13	A13	XTAL	O	Crystal oscillator output	92	E12	VSS	-	Ground
14	A14	XTAL	I	Crystal oscillator input (16.9344 MHz)	93	E13	VCCQ	-	Power supply +3.3 V
15	A15	VSS	-	Ground	94	E14	VSS	-	Ground
16	A16	CS7N/PJ6	O	SH2A-CPU chip select 7	95	E15	VDD	-	Power supply +1.2 V
17	A17	TRSTN	I	JTAG test reset input	96	E16	VDD	-	
18	A18	TDI	I	JTAG test data input	97	E17	D31/PF7	I/O	SH2A-CPU data bus 31
19	A19	TCK	I	JTAG test clock input	98	E18	D30/PF6	I/O	SH2A-CPU data bus 30
20	A20	VCCQ	-	Power supply +3.3 V	99	E19	D29/PF5	I/O	SH2A-CPU data bus 29
21	B1	MD15	I/O	Wave memory data bus 15	100	E20	D28/PF4	I/O	SH2A-CPU data bus 28
22	B2	VSS	-	Ground	101	F1	MD2	I/O	Wave memory data bus 2
23	B3	AN3	I	ADC analog input 3	102	F2	MD3	I/O	Wave memory data bus 3
24	B4	ANO	I	ADC analog input 0	103	F3	MD4	I/O	Wave memory data bus 4
25	B5	VSS	-	Ground	104	F4	MD5	I/O	Wave memory data bus 5
26	B6	TxD1	O	Serial output 1	105	F5	VDD	-	Power supply +1.2 V
27	B7	TxD0	O	Serial output 0	106	F6	VDD	-	
28	B8	VSS	-	Ground	107	F7	D27/PF3	I/O	SH2A-CPU data bus 27
29	B9	FUNC_DP	I/O	USB function data +	108	F8	D26/PF2	I/O	SH2A-CPU data bus 26
30	B10	VSS	-	Ground	109	F9	D25/PF1	I/O	SH2A-CPU data bus 25
31	B11	HOST_DP	I/O	USB host data +	110	F20	D24/PF0	I/O	SH2A-CPU data bus 24
32	B12	SCL	I/O	E bus (I2C) clock input/output (5V compatible)	111	G1	MA2	O	Wave memory address bus 2
33	B13	VSS	-	Ground	112	G2	MA1	O	Wave memory address bus 1
34	B14	VSS	-		113	G3	MD0	I/O	Wave memory data bus 0
35	B15	CS4N/PJ3	O	SH2A-CPU chip select 4	114	G4	MD1	I/O	Wave memory data bus 1
36	B16	TIOC0A/PJ7	O	PWM output	115	G5	VSS	-	Ground
37	B17	TESTN	I	Test input	116	G6	VSS	-	
38	B18	TMS	I	JTAG test mode select input	117	G17	D23/PE7	I/O	SH2A-CPU data bus 23
39	B19	VCCQ	-	Power supply +3.3 V	118	G18	D22/PE6	I/O	SH2A-CPU data bus 22
40	B20	VCCQ	-		119	G19	D21/PE5	I/O	SH2A-CPU data bus 21
41	C1	MD13	I/O	Wave memory data bus 13	120	G20	D20/PE4	I/O	SH2A-CPU data bus 20
42	C2	MD14	I/O	Wave memory data bus 14	121	H1	MA6	O	Wave memory address bus 6
43	C3	VSS	-	Ground	122	H2	MA5	O	Wave memory address bus 5
44	C4	VREFADC	-	ADC reference power supply +3.3 V	123	H3	MA4	O	Wave memory address bus 4
45	C5	VSSADC	-	ADC analog ground	124	H4	MA3	O	Wave memory address bus 3
46	C6	VSS	-	Ground	125	H5	VCCQ	-	Power supply +3.3 V
47	C7	RxD0	I	Serial input 0	126	H6	VCCQ	-	
48	C8	VSS	-	Ground	127	H17	D19/PE3	I/O	SH2A-CPU data bus 19
49	C9	VBUS	I	USB cable connection monitor (5V compatible)	128	H18	D18/PE2	I/O	SH2A-CPU data bus 18
50	C10	VSS	-	Ground	129	H19	VCCQ	-	Power supply +3.3 V
51	C11	OVER_CURRENT_N	I	USB overcurrent detection (5V compatible)	130	H20	VCCQ	-	
52	C12	SDA	I/O	E bus (I2C) data input/output (5V compatible)	131	J1	MA10	O	Wave memory address bus 10
53	C13	CS0N	O	SH2A-CPU chip select 0	132	J2	MA9	O	Wave memory address bus 9
54	C14	CS2N/PJ1	O	SH2A-CPU chip select 2	133	J3	MA8	O	Wave memory address bus 8
55	C15	CS5N/PJ4	O	SH2A-CPU chip select 5	134	J4	MA7	O	Wave memory address bus 7
56	C16	ASEMDN	I	Debug mode configuration	135	J5	VSS	-	Ground
57	C17	TDO	O	JTAG test data output	136	J9	VSS	-	
58	C18	VCCQ	-	Power supply +3.3 V	137	J10	VSS	-	
59	C19	VDDPLL	-	PLL analog power supply +1.2 V	138	J11	VSS	-	
60	C20	VDDPLL	-		139	J12	VSS	-	
61	D1	MD10	I/O	Wave memory data bus 10	140	J16	VSS	-	
62	D2	MD11	I/O	Wave memory data bus 11	141	J17	D17/PE1	I/O	SH2A-CPU data bus 17
63	D3	MD12	I/O	Wave memory data bus 12	142	J18	D16/PE0	I/O	SH2A-CPU data bus 16
64	D4	VSS	-	Ground	143	J19	CKOEN	I	Clock output control for SDRAM
65	D5	VCCADC	-	ADC analog power supply +3.3 V	144	J20	CKIO	O	Clock output for SDRAM
66	D6	VSS	-	Ground	145	K1	MA14	O	Wave memory address bus 14
67	D7	RESN	I	Hardware reset	146	K2	MA13	O	Wave memory address bus 13
68	D8	VCCQ	-	Power supply +3.3 V	147	K3	MA12	O	Wave memory address bus 12
69	D9	PULLUP_ENB	O	USB pull-up enable	148	K4	MA11	O	Wave memory address bus 11
70	D10	VCCQ	-	Power supply +3.3 V	149	K5	VDD	-	Power supply +1.2 V
71	D11	UCTL	I	USB output control	150	K9	VSS	-	Ground
72	D12	EICN	O	E bus reset output	151	K10	VSS	-	
73	D13	CS1N/PJ0	O	SH2A-CPU chip select 1	152	K11	VSS	-	
74	D14	CS3N/PJ2	O	SH2A-CPU chip select 3	153	K12	VSS	-	
75	D15	CS6N/PJ5	O	SH2A-CPU chip select 6	154	K16	VDD	-	Power supply +1.2 V
76	D16	ASEBRKAKN	I/O	Emulator break	155	K17	CKE	O	Clock enable for SDRAM
77	D17	VCCQ	-	Power supply +3.3 V	156	K18	D15	I/O	SH2A-CPU data bus 15
78	D18	VCCQ	-		157	K19	VSS	-	Ground
79	D19	VSSPLL	-	PLL analog ground	158	K20	VSS	-	

PIN NO.	OUTER NO.	NAME	I/O	FUNCTION	PIN NO.	OUTER NO.	NAME	I/O	FUNCTION
159	L1	MA15	O	Wave memory address bus 15	238	U2	PA6	I/O	Parallel port A6
160	L2	MA16	O	Wave memory address bus 16	239	U3	PA7	I/O	Parallel port A7
161	L3	MA17	O	Wave memory address bus 17	240	U4	VCCQ	-	Power supply +3.3 V
162	L4	MA18	O	Wave memory address bus 18	241	U5	ED1/PC1	I/O	External CPU data bus 1
163	L5	VDD	-	Power supply +1.2 V	242	U6	ED5/PC5	I/O	External CPU data bus 5
164	L9	VSS	-	Ground	243	U7	ED9/PD1	I/O	External CPU data bus 9
165	L10	VSS	-		244	U8	ED13/PD5	I/O	External CPU data bus 13
166	L11	VSS	-		245	U9	EA2/PK1	I	External CPU address bus 2
167	L12	VSS	-		246	U10	ECSN	I	External CPU chip select
168	L16	VDD	-	Power supply +1.2 V	247	U11	BCLK	O	Bit clock output
169	L17	D11	I/O	SH2A-CPU data bus 11	248	U12	IRQ0	I	Interrupt input 0
170	L18	D12	I/O	SH2A-CPU data bus 12	249	U13	A25	O	SH2A-CPU address bus 25
171	L19	D13	I/O	SH2A-CPU data bus 13	250	U14	A21	O	SH2A-CPU address bus 21
172	L20	D14	I/O	SH2A-CPU data bus 14	251	U15	A17	O	SH2A-CPU address bus 17
173	M1	MA19	O	Wave memory address bus 19	252	U16	A13	O	SH2A-CPU address bus 13
174	M2	MA20	O	Wave memory address bus 20	253	U17	VCCQ	-	Power supply +3.3 V
175	M3	MA21	O	Wave memory address bus 21	254	U18	A3	O	SH2A-CPU address bus 3
176	M4	MA22	O	Wave memory address bus 22	255	U19	A2	O	SH2A-CPU address bus 2
177	M5	VSS	-	Ground	256	U20	A1	O	SH2A-CPU address bus 1
178	M9	VSS	-		257	V1	PB0	I/O	Parallel port B0
179	M10	VSS	-		258	V2	PB1	I/O	Parallel port B1
180	M11	VSS	-		259	V3	VCCQ	-	Power supply +3.3 V
181	M12	VSS	-	260	V4	PB6	I/O	Parallel port B6	
182	M16	VSS	-	261	V5	ED2/PC2	I/O	External CPU data bus 2	
183	M17	D7	I/O	SH2A-CPU data bus 7	262	V6	ED6/PC6	I/O	External CPU data bus 6
184	M18	D8	I/O	SH2A-CPU data bus 8	263	V7	ED10/PD2	I/O	External CPU data bus 10
185	M19	D9	I/O	SH2A-CPU data bus 9	264	V8	ED14/PD6	I/O	External CPU data bus 14
186	M20	D10	I/O	SH2A-CPU data bus 10	265	V9	EA3/PK2	I	External CPU address bus 3
187	N1	MA23/PG4	O	Wave memory address bus 23	266	V10	SDIO/PK5	I	Serial audio input 0
188	N2	MA24/PG5	O	Wave memory address bus 24	267	V11	WCLK2/SD02	O	Word clock output 2/Serial audio output 2
189	N3	MA25/PG6	O	Wave memory address bus 25	268	V12	IRQ1	I	Interrupt input 1
190	N4	MA26/PG7	O	Wave memory address bus 26	269	V13	BW_MD0	I	SH2A-CPU data bus width configuration
191	N5	VCCQ	-	Power supply +3.3 V	270	V14	A22/PH5	O	SH2A-CPU address bus 22
192	N16	VCCQ	-		271	V15	A18	O	SH2A-CPU address bus 18
193	N17	D3	I/O	SH2A-CPU data bus 3	272	V16	A14	O	SH2A-CPU address bus 14
194	N18	D4	I/O	SH2A-CPU data bus 4	273	V17	A10	O	SH2A-CPU address bus 10
195	N19	D5	I/O	SH2A-CPU data bus 5	274	V18	VCCQ	-	Power supply +3.3 V
196	N20	D6	I/O	SH2A-CPU data bus 6	275	V19	A5	O	SH2A-CPU address bus 5
197	P1	MCS3N/PG3	O	Wave memory chip select 3	276	V20	A4	O	SH2A-CPU address bus 4
198	P2	MCS2N/PG2	O	Wave memory chip select 2	277	W1	PB2	I/O	Parallel port B2
199	P3	MCS1N/PG1	O	Wave memory chip select 1	278	W2	VCCQ	-	Power supply +3.3 V
200	P4	MWRN/PG0	O	Wave memory write enable	279	W3	PB4	I/O	Parallel port B4
201	P5	VSS	-	Ground	280	W4	PB7	I/O	Parallel port B7
202	P16	VSS	-		281	W5	ED3/PC3	I/O	External CPU data bus 3
203	P17	RD/WRN	O	SH2A-CPU read/write enable	282	W6	ED7/PC7	I/O	External CPU data bus 7
204	P18	D0	I/O	SH2A-CPU data bus 0	283	W7	ED11/PD3	I/O	External CPU data bus 11
205	P19	D1	I/O	SH2A-CPU data bus 1	284	W8	ED15/PD7	I/O	External CPU data bus 15
206	P20	D2	I/O	SH2A-CPU data bus 2	285	W9	ERDN/PK3	I	External CPU read enable
207	R1	MCS0N	O	Wave memory chip select 0	286	W10	SDI1/PK6	I	Serial audio input 1
208	R2	MRDN	O	Wave memory read enable	287	W11	WCLK	O	Word clock output
209	R3	BTCHG	I	BOOT ROM switching control	288	W12	SYSCLK2	O	Clock output 2
210	R4	PA0	I/O	Parallel port A0	289	W13	WAITN/PK7	I	External wait input
211	R5	VDD	-	Power supply +1.2 V	290	W14	A23/PH6	O	SH2A-CPU address bus 23
212	R16	VDD	-		291	W15	A19	O	SH2A-CPU address bus 19
213	R17	WE3/DQM/U/PH3	O	Writing byte of D31 - D24/Selecting D31 - D24 in case of SDRAM	292	W16	A15	O	SH2A-CPU address bus 15
214	R18	RASLN	O	RAS output for SDRAM	293	W17	A11	O	SH2A-CPU address bus 11
215	R19	CASLN	O	CAS output for SDRAM	294	W18	A8	O	SH2A-CPU address bus 8
216	R20	RDN	O	SH2A-CPU read enable	295	W19	VCCQ	-	Power supply +3.3 V
217	T1	PA1	I/O	Parallel port A1	296	W20	A6	O	SH2A-CPU address bus 6
218	T2	PA2	I/O	Parallel port A2	297	Y1	VCCQ	-	Power supply +3.3 V
219	T3	PA3	I/O	Parallel port A3	298	Y2	PB3	I/O	Parallel port B3
220	T4	PA4	I/O	Parallel port A4	299	Y3	PB5	I/O	Parallel port B5
221	T5	VDD	-	Power supply +1.2 V	300	Y4	ED0/PC0	I/O	External CPU data bus 0
222	T6	VDD	-		301	Y5	ED4/PC4	I/O	External CPU data bus 4
223	T7	VSS	-	Ground	302	Y6	ED8/PD0	I/O	External CPU data bus 8
224	T8	VCCQ	-	Power supply +3.3 V	303	Y7	ED12/PD4	I/O	External CPU data bus 12
225	T9	VSS	-	Ground	304	Y8	EA1/PK0	I	External CPU address bus 1
226	T10	VCCQ	-	Power supply +3.3 V	305	Y9	EWRN/PK4	I	External CPU write enable
227	T11	VCCQ	-		306	Y10	SDO0	O	Serial audio output 0
228	T12	VSS	-	Ground	307	Y11	SDO1	O	Serial audio output 1
229	T13	VCCQ	-	Power supply +3.3 V	308	Y12	SYSCLK	O	Clock output
230	T14	VSS	-	Ground	309	Y13	SYI	I	Sync. input from external device
231	T15	VDD	-	Power supply +1.2 V	310	Y14	A24/PH7	O	SH2A-CPU address bus 24
232	T16	VDD	-		311	Y15	A20	O	SH2A-CPU address bus 20
233	T17	A0/PH4	O	SH2A-CPU address bus 0	312	Y16	A16	O	SH2A-CPU address bus 16
234	T18	WE0/DQM/LU/PH0	O	Writing byte of D7 - D0/Selecting D7 - D0 in case of SDRAM	313	Y17	A12	O	SH2A-CPU address bus 12
235	T19	WE1/DQM/LU/PH1	O	Writing byte of D15 - D8/Selecting D15 - D8 in case of SDRAM	314	Y18	A9	O	SH2A-CPU address bus 9
236	T20	WE2/DQM/LU/PH2	O	Writing byte of D23 - D16/Selecting D23 - D16 in case of SDRAM	315	Y19	A7	O	SH2A-CPU address bus 7
237	U1	PA5	I/O	Parallel port A5	316	Y20	VCCQ	-	Power supply +3.3 V

● S1D13700F01A100 (X5422A00) LCD CONTROLLER

DM: IC4

PIN NO.	NAME	I/O	FUNCTION	PIN NO.	NAME	I/O	FUNCTION		
1	VSS	I	Ground	33	VSS	I	Ground		
2	AB12	I		Address bus	34	XCD1		O	Drain output
3	AB11	I	Address bus		35	XCG1	I	Gate input	
4	AB10	I			Address bus	36	RESET#	I	Reset
5	AB9	I	Address bus			37	SCANEN	I	Test mode set up input
6	AB8	I			Power supply	38	TESTEN	I	
7	HIOVDD	I	Power supply			39	CLKI	I	Power supply
8	AB7	I			Address bus	40	COREVDD	I	
9	AB6	I	Address bus	41		RD#	I	Write strobe	
10	AB5	I		Power supply	42	WR#	I		Chip select
11	AB4	I	Power supply		43	CS#	I	Data bus	
12	COREVDD	I		Address bus	44	DB7	I/O		Data bus
13	AB3	I	Address bus		45	DB6	I/O		
14	AB2	I		Address bus	46	DB5	I/O		
15	AB1	I	Ground		47	DB4	I/O	Data bus	
16	AB0	I		Ground	48	HIOVDD	I		Ground
17	VSS	I	Data bus		49	DB3	I/O		
18	FPDAT3	O		Data bus	50	DB2	I/O		
19	FPDAT2	O	Data bus		51	DB1	I/O	Input pin for S1D 13700 setting	
20	FPDAT1	O		Power supply	52	DB0	I/O		Input pin for S1D 13700 setting
21	FPDAT0	O	Shift clock		53	VSS	I		
22	NIOVDD	I		Shift clock	54	WAIT#	O		
23	FPSHIFT	O	X driver enable chain clock		55	HIOVDD	I	Address bus	
24	XECL	O		Power supply	56	CNF0	I		Address bus
25	COREVDD	I	Latch pulse		57	CNF1	I		
26	FPLINE	O		Frame signal	58	CNF2	I		
27	MOD	O	Ground		59	CNF3	I	Address bus	
28	VSS	I		Scan shift clock	60	CNF4	I		Address bus
29	YSCL	O	Scan start pulse		61	AS#	I		
30	FPFRAME	O		LCD power-down output	62	AB15	I		
31	YDIS	O	Power supply		63	AB14	I	Address bus	
32	NIOVDD	I		Power supply	64	AB13	I		Address bus

● UPD789022GB-A15-8E (XZ56010R) CPU (MKS)

DM: IC17

PIN NO.	NAME	I/O	FUNCTION	PIN NO.	NAME	I/O	FUNCTION	
1	P12	I/O	Port 1	23	P32/INTP2/CPT2	I/O	Port 3/External interrupt input/Capture edge input	
2	P11	I/O		Port 1	24	P31/INTP1		I/O
3	P10	I/O			Port 1	25	P30/INTP0	I/O
4	P47/KR7	I/O		Port 4/Key return signal detection input		26	P22/RXD/SIO	I/O
5	P46/KR6	I/O	Port 4/Key return signal detection input		27	P21/TXD/SO0	I/O	Port 2/Asynchronous serial interface serial clock input/Serial interface serial clock
6	P45/KR5	I/O		Port 4/Key return signal detection input	28	P20/ASCK/SCK0	I/O	
7	P44/KR4	I/O	Port 4/Key return signal detection input		29	P07	I/O	Port 0
8	P43/KR3	I/O		Port 4/Key return signal detection input	30	P06	I/O	
9	P42/KR2	I/O	Port 4/Key return signal detection input		31	P05	I/O	Port 0
10	P41/KR1	I/O		Port 4/Key return signal detection input	32	P04	I/O	
11	P40/KR0	I/O	Port 4/Key return signal detection input		33	P03	I/O	Port 0
12	NC			Internally connected (N.C.)	34	P02	I/O	
13	IC		Internally connected (N.C.)		35	P01	I/O	Port 0
14	X2	I		Clock	36	P00	I/O	
15	X1	I	Clock		37	NC		Port 0
16	VSS0	I		Ground	38	VDD1	I	
17	VDD0	I	Power supply		39	VSS1	I	Ground
18	/RESET	I		System reset	40	P17	I/O	
19	P53	I/O	Port 5		41	P16	I/O	Port 1
20	P52	I/O		Port 5	42	P15	I/O	
21	P51/TO2	I/O	Port 5/16-bit timer output		43	P14	I/O	Port 1
22	P50/TIO/TO0	I/O		Port 5/External count clock input to 8-bit timer/8-bit timer output	44	P13	I/O	

IC BLOCK DIAGRAM (IC ブロック図)

- **SN74LV08APWR** (X4463A00)

DM: IC13

- **SN74AHCT08PWR** (X3824A00)

DM: IC24

Quad 2 Input AND

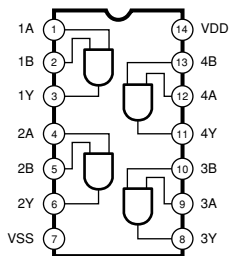

- **SN74LV14APWR** (X6688A0R)

Hex Inverter

DM: IC20

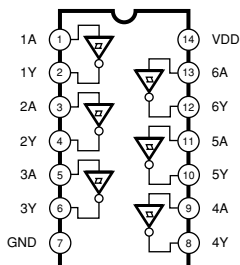

- **NJM4580E(TE2)** (X2331A0R)

Dual Operational Amplifier

DM: IC16

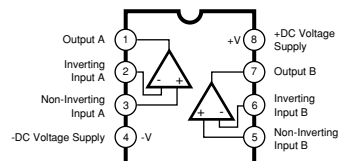

- **LA4625** (XY209A0R)

Power Amplifier 13.5W

AM: IC201

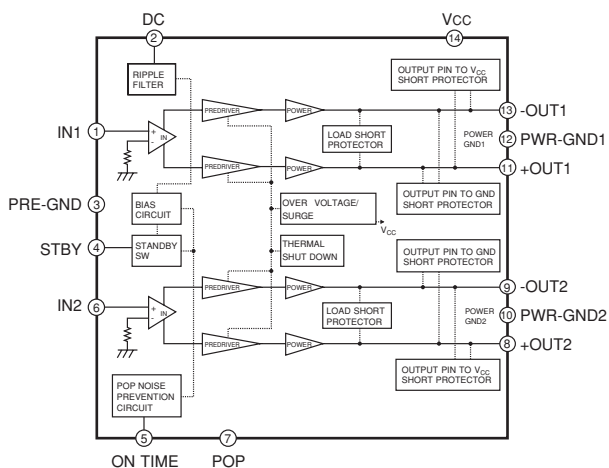

- **MC34063EBD-TR** (X7371A00)

DC-DC Converter

DM: IC19

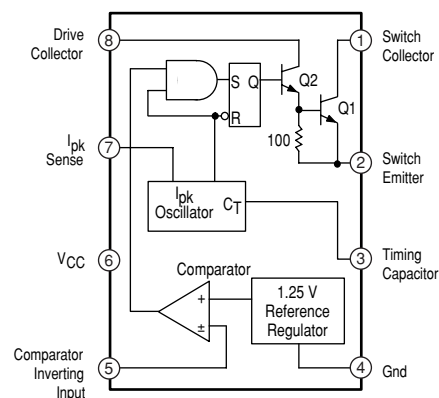

- **R5520H001B-T1-F** (X7569A00)

USB High-Side Power Switch

DM: IC18

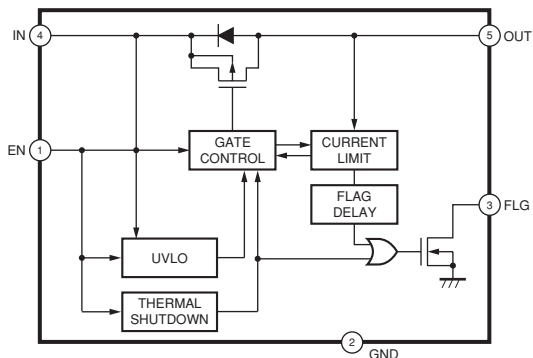
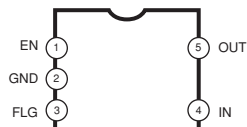

■ CIRCUIT BOARDS (シート基板図)

CONTENTS (目次)

●61H Circuit Board (X2335C0)	32
●61L Circuit Board (X2336B0)	32
●AM Circuit Board (X7722C0)	24
●DM Circuit Board (X9574B0)	22
●ENC Circuit Board (X7722C0)	25
●JACK Circuit Board (X7722C0)	25
●MVR Circuit Board (X7722C0)	24
●PB Circuit Board (X7722C0)	24
●PNC Circuit Board (X7978B0)	28
●PNL Circuit Board (X7723D0)	26
●PNR Circuit Board (X7978B0)	30
●PSW Circuit Board (X7722C0)	25
●TW Circuit Board (X7722C0)	25

Note: See parts list for details of circuit board component parts.
 注：シートの部品詳細はパーツリストをご参照ください。

• DM Circuit Board

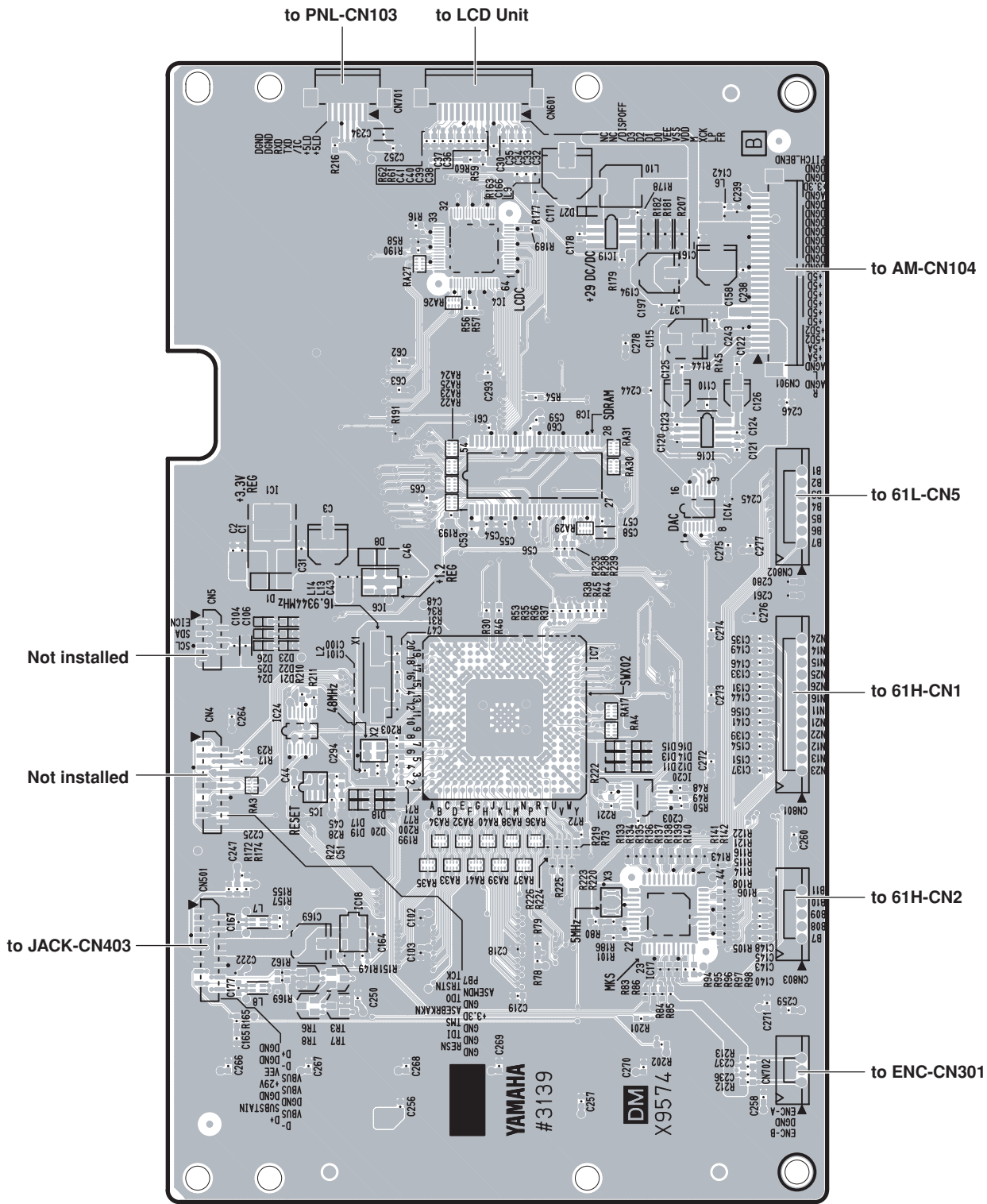

Component Side (部品側)

2NA-WH33370

• DM Circuit Board

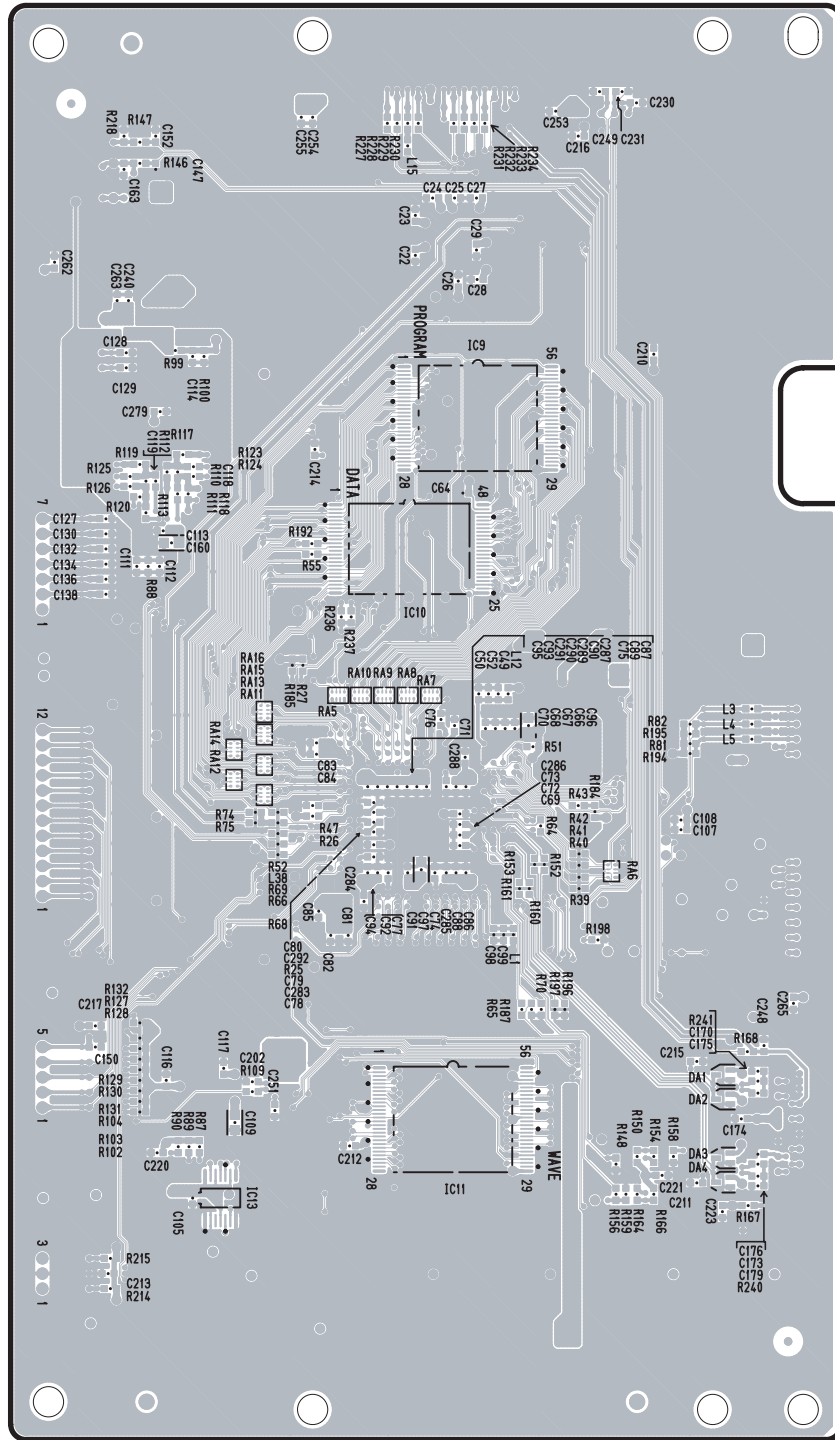

Pattern Side (パターン側)

2NA-WH33370

• MVR Circuit Board

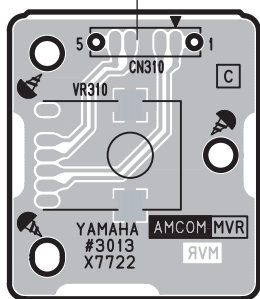

MASTER VOLUME
Component Side (部品側)

• AM Circuit Board

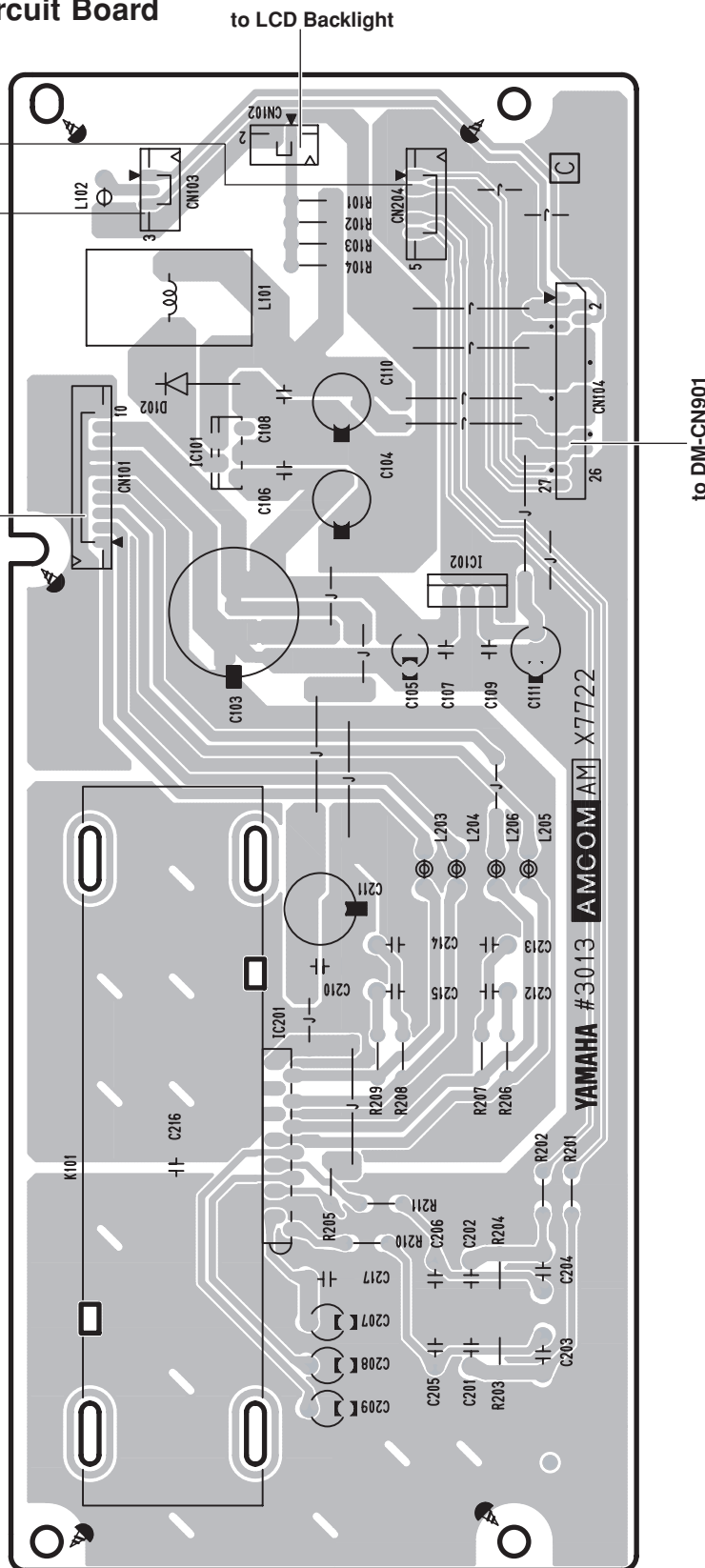

Component Side (部品側)

AM: 2NA-WH33410
MVR: 2NA-WH33410
PB: 2NA-WH33410

• PB Circuit Board

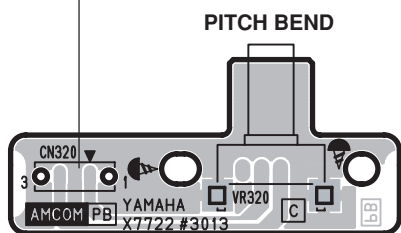

Component Side (部品側)

• JACK Circuit Board

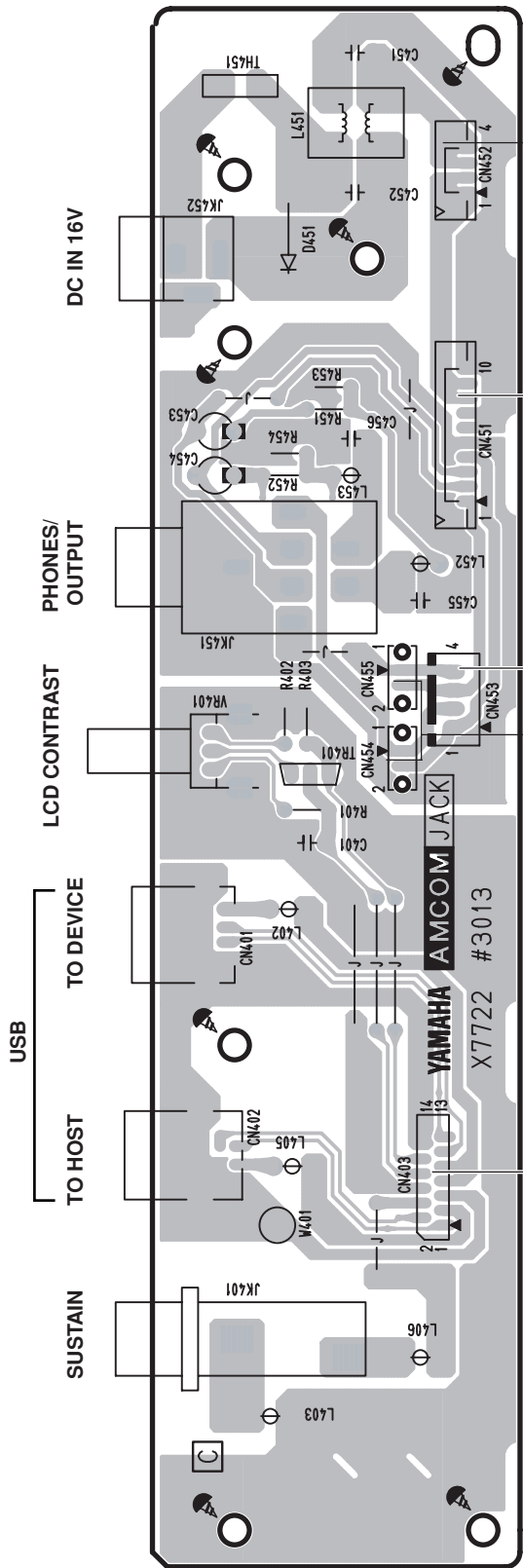

Component Side (部品側)

- JACK: 2NA-WH33410
- PSW: 2NA-WH33410
- ENC: 2NA-WH33410
- TW: 2NA-WH33410

• PSW Circuit Board

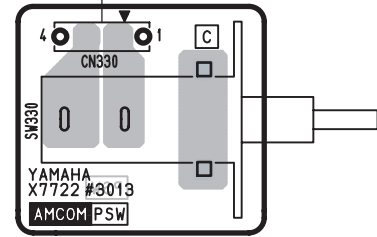

STANDBY/ON
Component Side (部品側)

• ENC Circuit Board

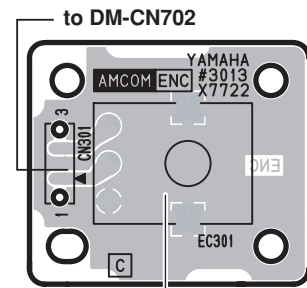

Rotary Encoder
Component Side (部品側)

• TW Circuit Board

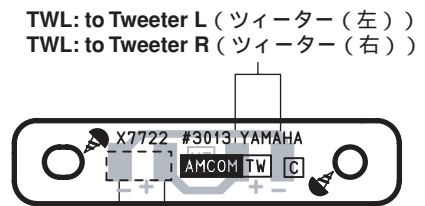

Component Side (部品側)

to AM-CN101
to Woofer L (ウーファー (左))
to Woofer R (ウーファー (右))

to DM-CN501

•PNL Circuit Board

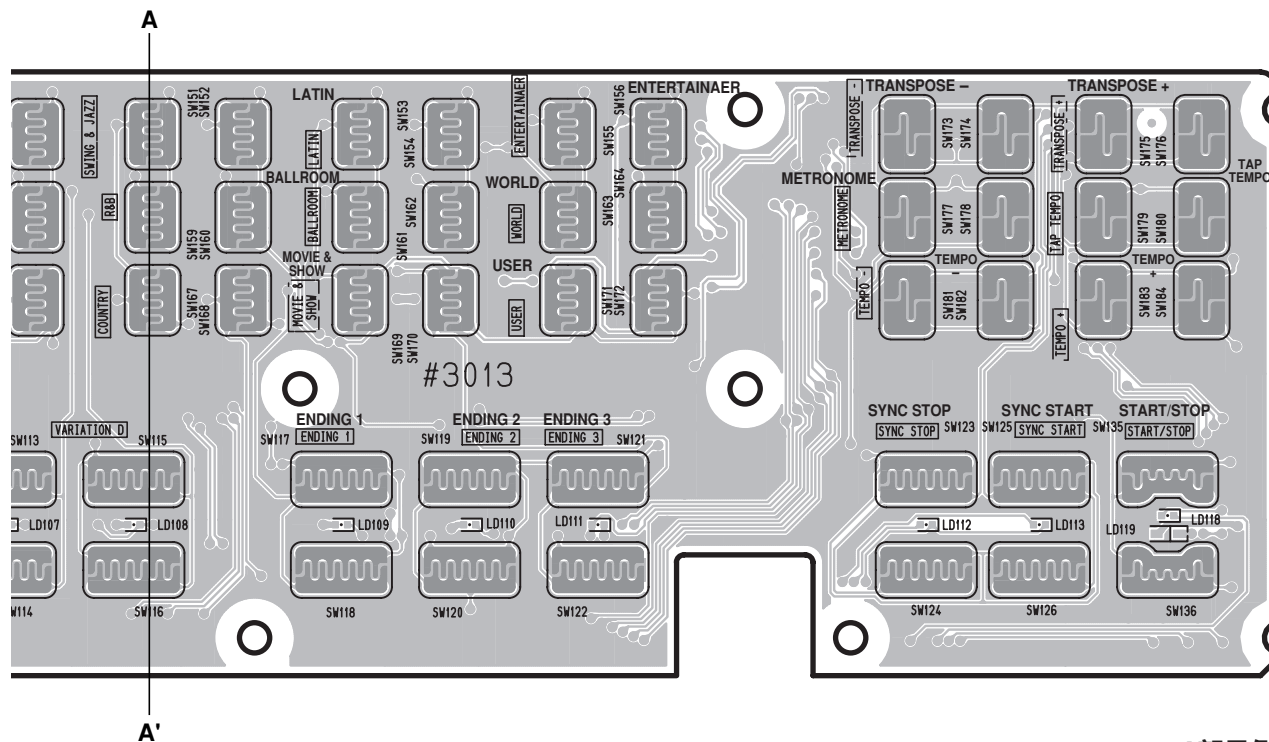
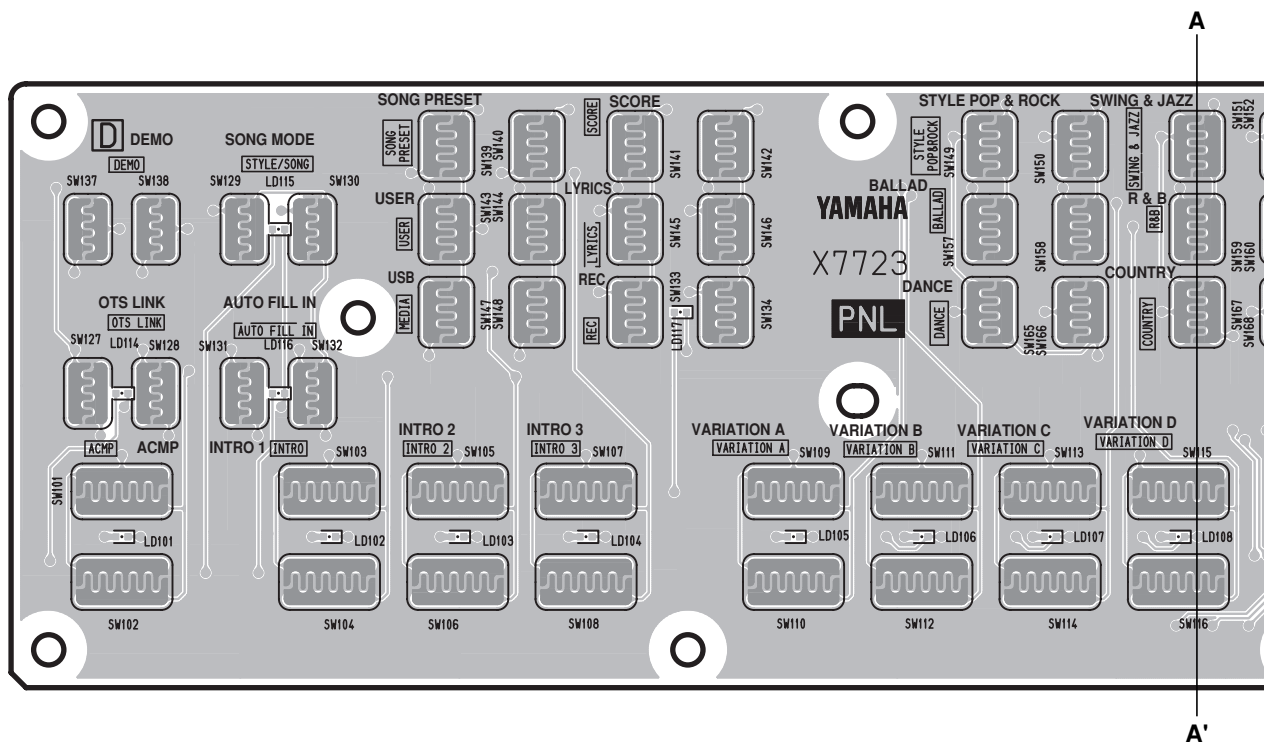

Component Side (部品側)

•PNC Circuit Board

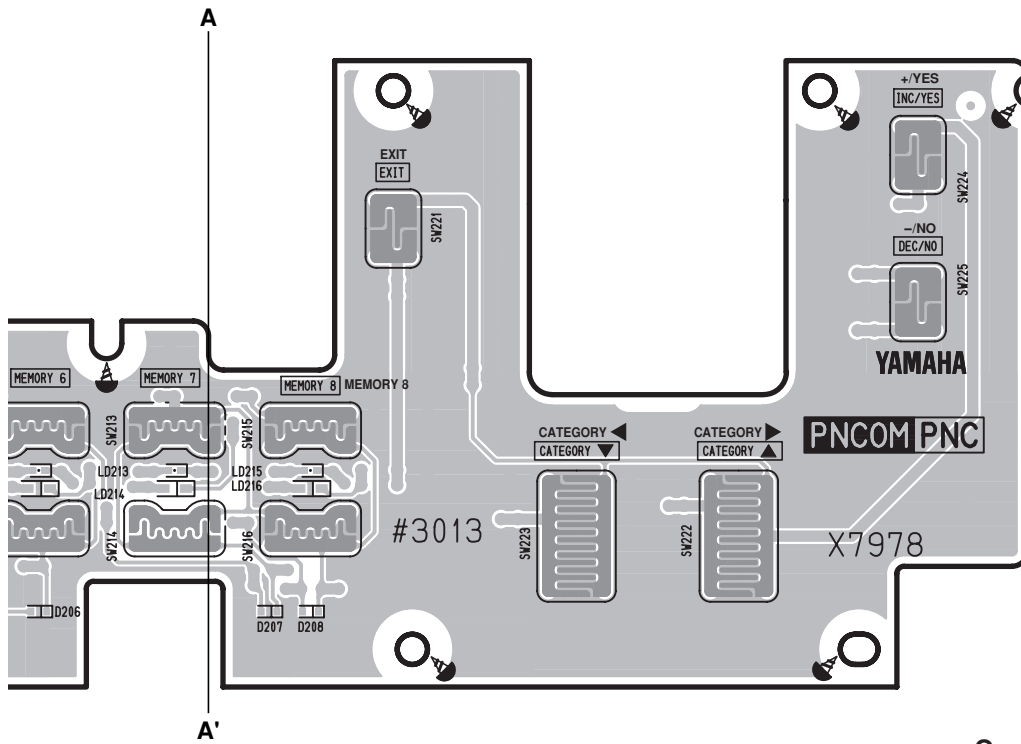
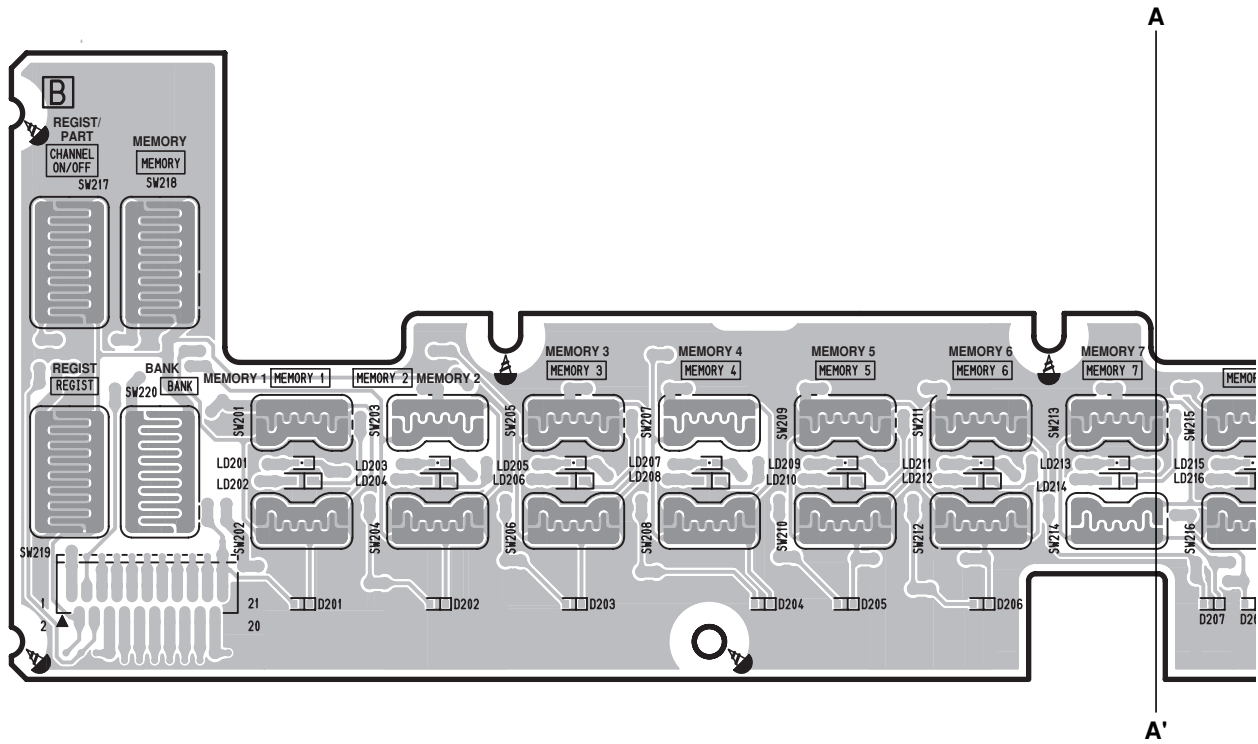

Component Side (部品側)

•PNC Circuit Board

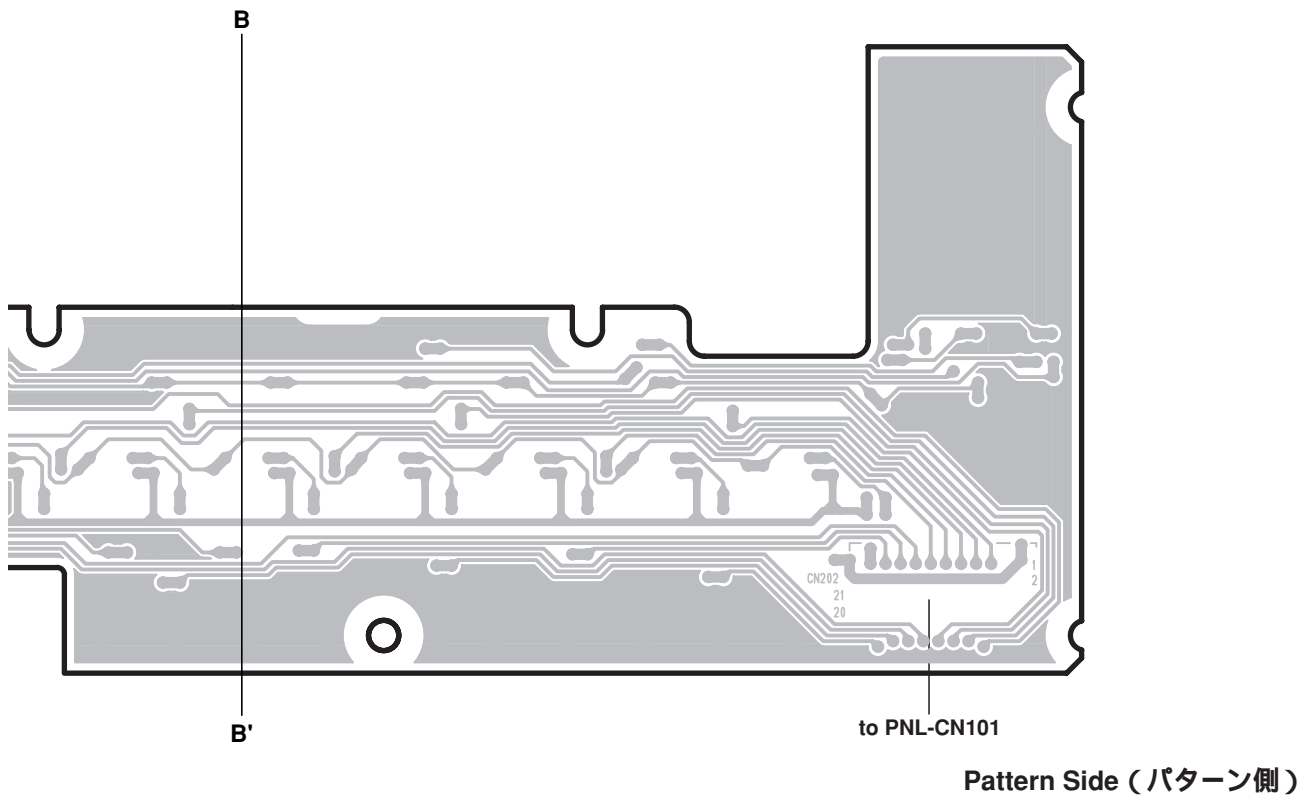
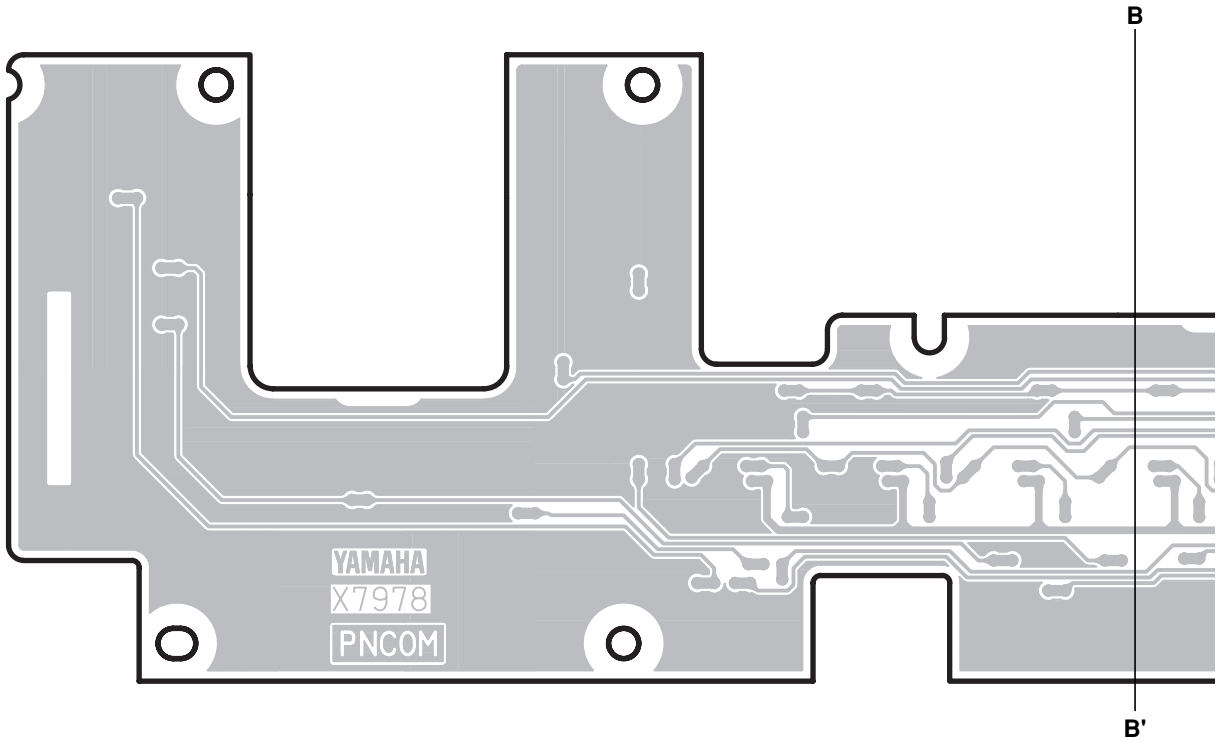

•PNR Circuit Board

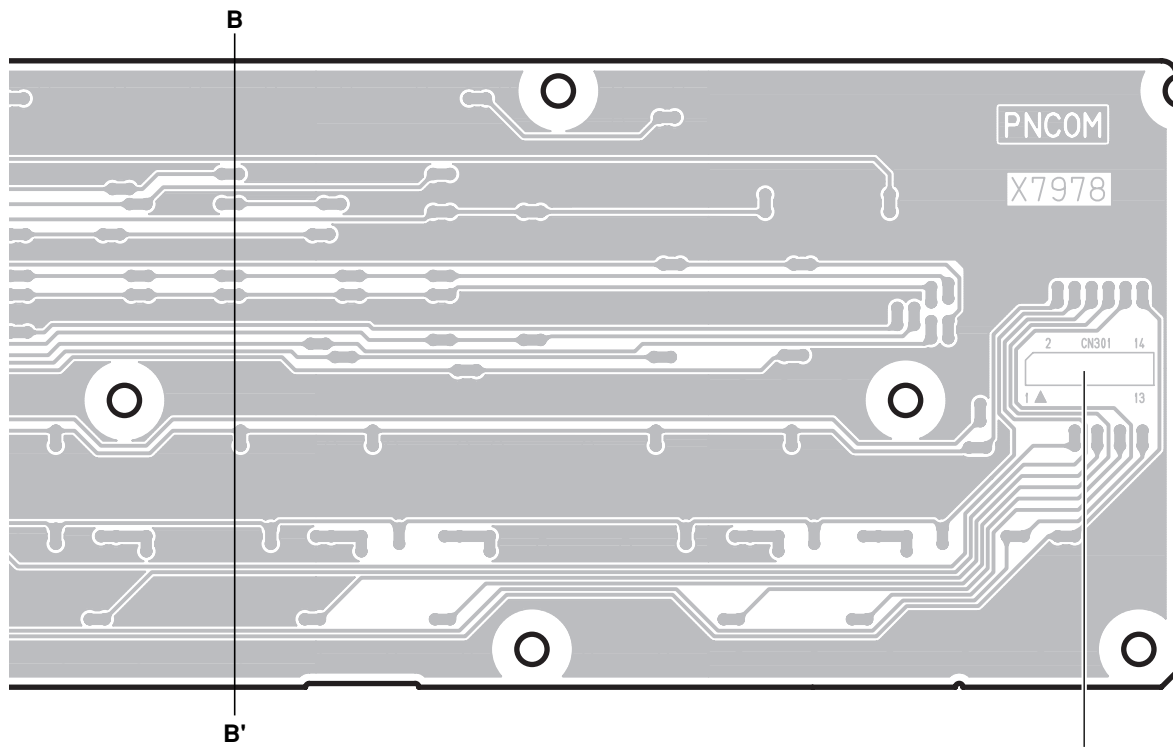
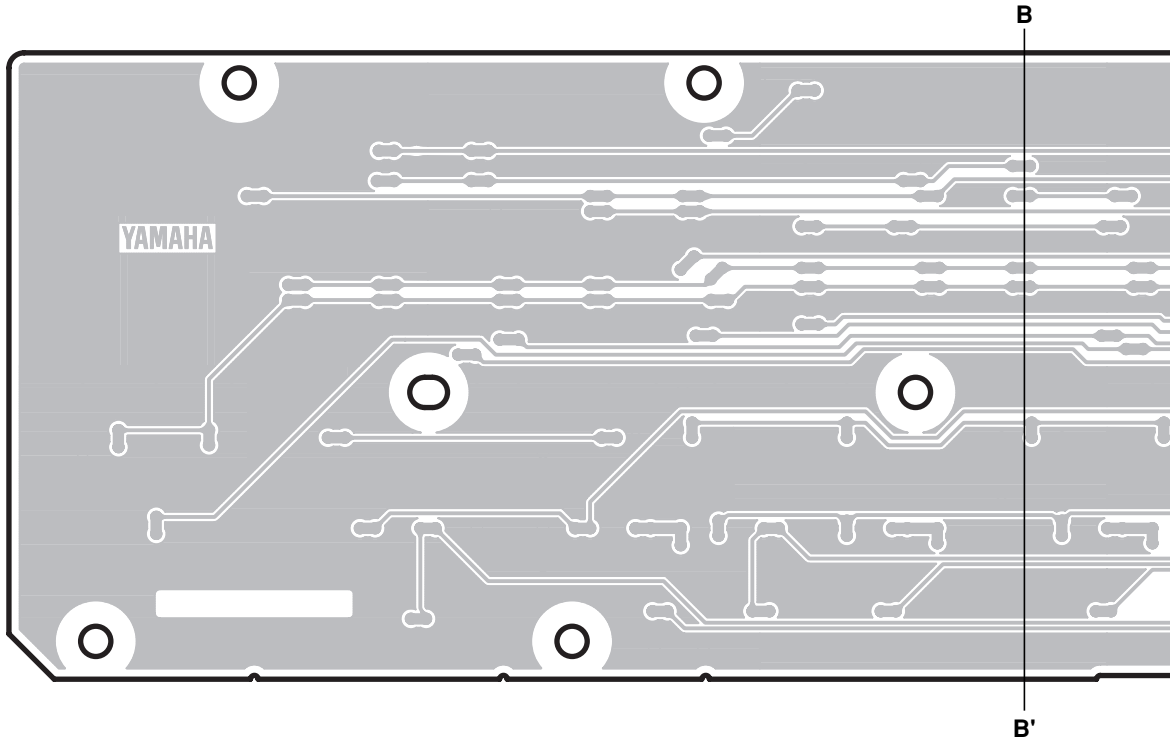

to PNL-CN102
Pattern Side (パターン側)

● 61H Circuit Board

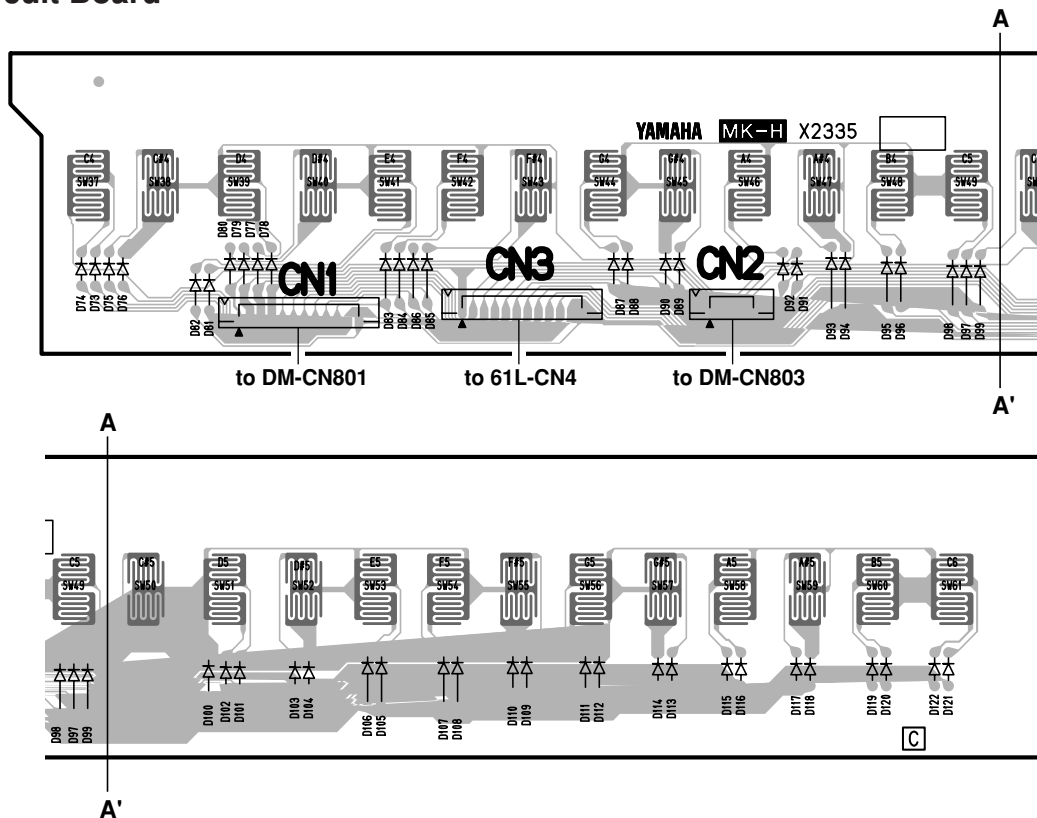

● 61L Circuit Board

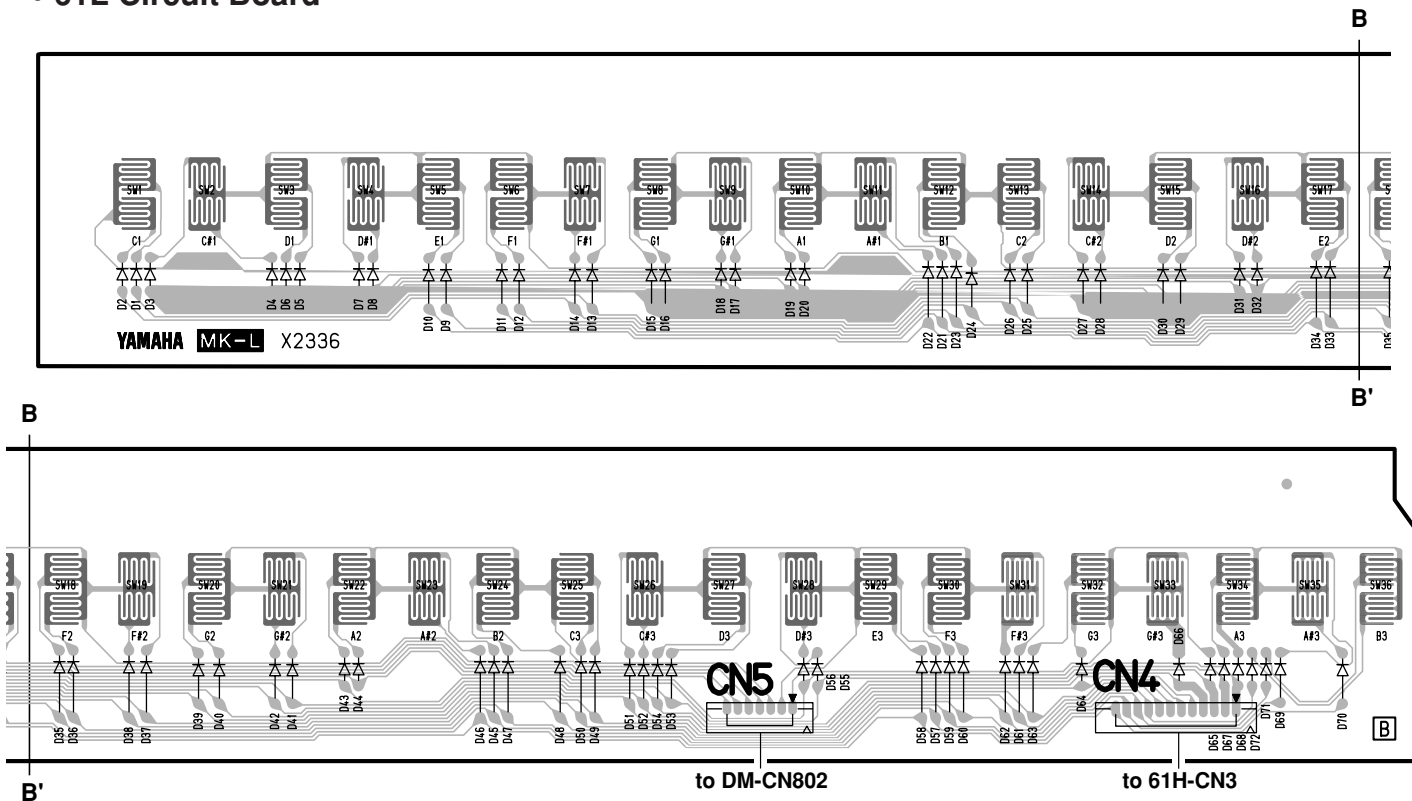

61H: 2NAKB-V869540
 61L: 2NAKB-V869520

■ TEST PROGRAM

* *If you execute the test No.49 (Factory Set), then the user's preset data may be lost. Therefore, back up the user's data in advance.*

A. PREPARATION

- 1) PA-301 or PA-300B (AC adaptor) is used.
- 2) Measuring instruments: frequency counter, level meter (with JIS-C filter)
Note: Connect a stereo plug to the [PHONES/OUTPUT] jack at 33 Ω.
- 3) Jigs: Foot switch (FC-4 or FC-5), USB cable, USB flash memory, USB-MIDI driver (*1)
PC (Install a USB-MIDI driver (*1) in PC and finish the THROUGH setup.)

*1 Obtain the USB-MIDI driver from CD-ROM(X9448A00) for PSR-S550/PSR-S550B or Yamaha official website.
(URL>><http://www.yamahapclub.com>)

B. HOW TO ENTER THE TEST PROGRAM

While pressing the C2#, F2 and G2# keys, turn the [STANDBY/ON] switch on.

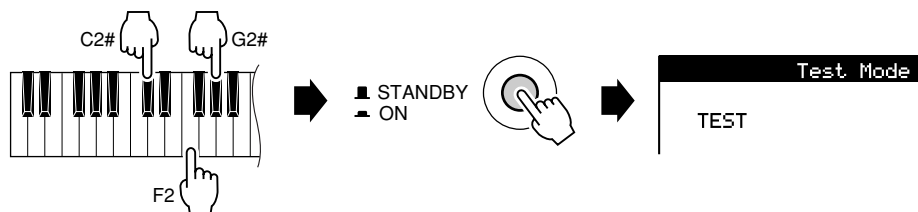

C. TEST PROCEDURE

- 1) When the test program is started, "TEST" will be displayed on the LCD.
- 2) Press the [+ / YES] or [- / NO] button to select a test program item.
- 3) Press the [START / STOP] button to execute the test.

- * If the test result is OK, or the test item is completed, press the [START / STOP] button again to return to the test item selection display.
Proceed to the next test by pressing the [-] or [+] button.
- * Press the [-] or [+] button of the number buttons to select the next test program item.
- * When the test result is OK, an asterisk (*) is added in front of its item name on display.
If the test result is NG, press the [DEMO] button or the lowest (leftmost) white key to return to the item selection display.

D. Test Item List

TEST No.	LCD Display	Test Descriptions, Judgment Criteria
--	--	Contrast Check Set the contrast knob to the legible position of LCD. When the contrast knob is turned clockwise (or counterclockwise), the LCD becomes blue (or white).
1	001 Version	Displays ROM versions (Prog, Wave). (In case of OK: "XXX" Prog / Wave, NG: "Err" Prog / Wave)
2	002 Rom Chk1	Checks the ROM that is connected to the CPU bus. The test results appear on the LCD. Check that the LCD displays "Rom OK". (OK: "Rom OK", NG: "Rom NG")

D. Test Item List

TEST No.	LCD Display	Test Descriptions, Judgment Criteria
3	003 Ram Chk1	Checks the RAM that is connected to the CPU bus. The test results appear on the LCD. Check that the LCD displays "Ram OK". (OK:"Ram OK", NG:"Ram NG")
4	004 Flash Rom Chk1	Checks the flash ROM that is connected to CPU bus. The check result appears on the LCD. Check that the LCD displays "Flash Ram OK". (OK:"Flash Rom OK", NG:"Flash Rom NG")
5	005 Wave Rom Chk1	Checks the wave ROM that is connected to CPU bus. The check result appears on the LCD. Check that the LCD displays "Wave OK". (OK:"Wave OK", NG:"Wave NG")
7	007 TG1 Chk	Outputs the sine wave by changing the channels in sequence from C2 to G4.[32 notes] Check the sound by hearing that there is no noise or abnormal sound. After auto-scaling is finished, individual keys can be played. (If playing two or more keys simultaneously, the first pressed key has priority to make a sound.)
8	008 Pit Chk	Connect the frequency counter to the [PHONES/OUTPUT] jack L or R. Check that the correct signal is produced. (441.0 Hz \pm 0.2 Hz)
	--	Volume Decrescence Check Connect the level meter(with a JIS-C filter) to the [PHONES/OUTPUT] jack. (33 Ω load) Set the [MASTER VOLUME] at minimum and check the output level. PHONES L : less than -70.0 dBu PHONES R : -70.0 dBu (dBu=dBm)
9	009 Output R	Connect the level meter (with a JIS-C filter) to the [PHONES/OUTPUT] jack. (33 Ω load) Set the [MASTER VOLUME] at maximum and check the output level (1 kHz sine wave, PAN=R). PHONES L : less than -45.0 dBu PHONES R : -5.5 dBu \pm 2 dB
10	010 Output L	Connect the level meter (with a JIS-C filter) to the [PHONES/OUTPUT] jack. (33 Ω load) Set the [MASTER VOLUME] at maximum and check the output level (1 kHz sine wave, PAN=L). PHONES L : -5.5 dBu \pm 2 dB PHONES R : less than -45.0 dBu
18	018 SW Chk	Checks the switches on the panel. Press the switches on the LCD as instructed. A pre-assigned note is output when the switch is pressed. A rotary encoder is clockwise set up to UP and is counterclockwise set to DOWN. (See P.36 "Table 1".) The check result appears on the LCD when all the switches are pressed as instructed. Check that "SW OK" is displayed. Also, check that no key stick is existed. (OK:"SW OK", NG:"SW NG", When multiple switches are pressed at the same time:"Over Two")
19	019 All LED Chk	Check that all the LEDs on the panel are on.
20	020 Red LED Chk	Check that all the red LEDs on the panel are on.
21	021 Green LED Chk	Check that all the green LEDs on the panel are on.
22	022 LCD On	Check that all LCD dots are on. (The whole screen becomes white.)
23	023 LCD Off	Check that all LCD dots are off. (The whole screen becomes blue.)

TEST No.	LCD Display	Test Descriptions, Judgment Criteria
29	029 Pedal4 Chk	<p>Connect the foot switch (FC-4 or FC-5) to the [SUSTAIN] jack.</p> <p>Check that the C3 note is output when the [START/STOP] button is pressed while stepping the pedal and the C4 note is output when releasing the pedal.</p> <p>The sound stops when stepping the pedal again. Check that the LCD displays "Pedal4 OK". (OK:"Pedal4 OK", NG:"Pedal4 NG")</p>
30	030 Pitch Bend Chk	<p>Checks the pitch bend wheel.</p> <p>(First, it checks if the center position of the wheel is correct or not.)</p> <p>Check that the C3 note is output when rotating the [PITCH BEND] wheel to minimum and the C4 note is output when rotating it to maximum. (OK:"Pitch Bend OK", NG:"Pitch Bend NG", If the center position of the wheel is not correct:"Center NG")</p>
32	032 MIDI Chk	<p>Checks MIDI and USB.</p> <p>Connect the PC with a USB-MIDI driver installed and the [USB TO HOST] terminal using a USB cable, and execute the test.</p> <p>(As for the PC, install a USB-MIDI driver in the PC and finish the THROUGH setup, in advance.) Check that the C4 note is output and the LCD displays "MIDI OK". (OK:"MIDI OK", NG:"MIDI NG")</p>
33	033 USB Connect Chk	<p>Checks the USB connection.</p> <ol style="list-style-type: none"> Execute this test. "USB Connect1 --" is displayed on the LCD. Connect the [TO DEVICE] and [TO HOST] terminals using a USB cable. Make sure that the LCD display changes to "USB Connect2 --". Remove the USB cable from the [TO DEVICE] terminal, and insert a USB flash memory into the [TO DEVICE] terminal. Make sure the C4 note is output and "USB Connect OK" is displayed on the LCD. (OK:"USB Connect OK", NG:"USB Connect NG")
34	034 USB Storage Chk	<p>Checks the USB storage.</p> <p>Connect a USB flash memory to the [TO DEVICE] terminal, and execute the test. Make sure that "USB Storage OK" is displayed on the LCD. (OK:"USB Storage OK", NG:"USB Storage NG")</p>
44	044 Rom Chk2	<p>Checks the ROM that is connected to the CPU bus.</p> <p>The test result appears on the LCD. Check that the LCD displays "Rom OK". It takes about 3 seconds. (OK:"Rom OK", NG:"Rom NG")</p>
45	045 Ram Chk2	<p>Check the RAM that is connected to the CPU bus.</p> <p>The test results appear on the LCD. Check that the LCD displays "Ram OK". (OK:"Ram OK", NG:"Ram NG")</p>
46	046 Flash RomChk2	<p>Checks the flash ROM that is connected to CPU bus.</p> <p>The check result appears on the LCD. Check that the LCD displays "Flash Ram OK". It takes about 50 seconds. (OK:"Flash Rom OK", NG:"Flash Rom NG")</p>
47	047 Wave RomChk2	<p>Checks the wave ROM that is connected to CPU bus.</p> <p>The check result appears on the LCD. Check that the LCD displays "Wave Ram OK". It takes about 2 minutes. (OK:"Flash Rom OK", NG:"Flash Rom NG")</p>

TEST No.	LCD Display	Test Descriptions, Judgment Criteria
49	049 Factory Set	All backup domains are initialized and it changes into a factory-shipsments state when executing this test.
50	050 Test Exit	Exit from the test program after executing this test.
--	--	Noise Check (in the normal mode) Connect the level meter(with a JIS-C filter) to the [PHONES/OUTPUT] jack. (33 ohm load) Set the [MASTER VOLUME] at maximum and check that the noise level is within the range below. PHONES L/R : less than -78.0 dBu

* dBu=dBm

* Note: As for the test no.44 - 47, it takes time. If you want to skip them, press the [+ /YES] button several times to go to the test no.49 (Factory Set).

Table 1 (表 1)

ORDER (順番)	SWITCH NAME (S W名)	LED (付属LED)	NOTE (ノート番号)
1	DIAL UP		C2
2	DIAL DOWN		C#2
3	DEMO		D2
4	SONG MODE	RED	D#2
5	SONG PRESET		E2
6	SONG SCORE		F2
7	SONG USER		F#2
8	SONG LYRICS		G2
9	SONG USB		G#2
10	SONG REC	RED	A2
11	POP&ROCK		A#2
12	SWING&JAZZ		B2
13	LATIN		C3
14	ENTERTAINER		C#3
15	BALLAD		D3
16	R & B		D#3
17	BALLROOM		E3
18	WORLD		F3
19	DANCE		F#3
20	COUNTRY		G3
21	MOVIE&SHOW		G#3
22	USER		A3
23	TRANSPOSE -		A#3
24	TRANSPOSE +		B3
25	METRONOME		C4
26	TAP TEMPO		C#4
27	TEMPO -		D4
28	TEMPO +		D#4
29	REGIST/TRACK		E4
30	MEMORY		F4
31	EXIT		F#4
32	-/YES		G4
33	+ /NO		G#4
34	EXECUTE		A4
35	MDB		A#4
36	FILE MENU		B4
37	FUNCTION		C5
38	PIANO		C#5
39	GUITAR & BASS		D5
40	ORGAN		D#5
41	CHOIR		E5
42	ACCORDION & HARMONICA		F5
43	E.PIANO		F#5
44	SAXOPHONE		G5
45	TRUMPET		G#5
46	PAD		A5

ORDER (順番)	SWITCH NAME (S W名)	LED (付属LED)	NOTE (ノート番号)
47	PERCUSSION		A#5
48	STRINGS		B5
49	FLUTE & WOODWIND		C6
50	BRASS		C#6
51	SYNTH. & FX		D6
52	DRUM KIT		D#6
53	OTS LINK	RED	C2
54	AUTO FILL IN	RED	C#2
55	ACMP	RED	D2
56	INTRO 1	RED	D#2
57	INTRO 2	RED	E2
58	INTRO 3	RED	F2
59	MAIN A	RED	F#2
60	MAIN B	RED	G2
61	MAIN C	RED	G#2
62	MAIN D	RED	A2
63	ENDING 1	RED	A#2
64	ENDING 2	RED	B2
65	ENDING 3	RED	C3
66	SYNC STOP	RED	C#3
67	SYNC START	RED	D3
68	START/STOP	RED/GREEN	D#3
69	REGIST BANK -		E3
70	REGIST BANK +		F3
71	REG. MEMORY 1	RED/GREEN	F#3
72	REG. MEMORY 2	RED/GREEN	G3
73	REG. MEMORY 3	RED/GREEN	G#3
74	REG. MEMORY 4	RED/GREEN	A3
75	REG. MEMORY 5	RED/GREEN	A#3
76	REG. MEMORY 6	RED/GREEN	B3
77	REG. MEMORY 7	RED/GREEN	C4
78	REG. MEMORY 8	RED/GREEN	C#4
79	CATEGORY <		D4
80	CATEGORY >		D#4
81	O. T. S. 1	RED	E4
82	O. T. S. 2	RED	F4
83	O. T. S. 3	RED	F#4
84	O. T. S. 4	RED	G4
85	LEFT	RED	G#4
86	DUAL	RED	A4
87	HARMONY	RED	A#4
88	TOUCH	RED	B4
89	SUSTAIN	RED	C5
90	DSP	RED	C#5
91	UPPER OCT -		D5
92	UPPER OCT +		D#5

■ INITIALIZATION

This function erases all User Songs, User Styles, User MDB, and backup data in the instrument's internal memory and restores the initial default settings and data. The following initialization procedures are provided.

Backup Clear

To clear backup data to the internal memory, simultaneously hold the highest white key on the keyboard and turn the power on by pressing the [STANDBY/ON] switch.

The backed up data will be erased and the default values restored.

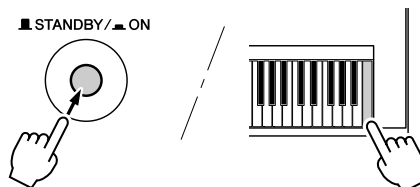

MEMORY Clear

To clear the User Song data, User Style data or User MDB data that has been transferred to the internal memory from a computer, simultaneously hold the highest white key on the keyboard and the three highest black keys and then turn the power on by pressing the [STANDBY/ON] switch.

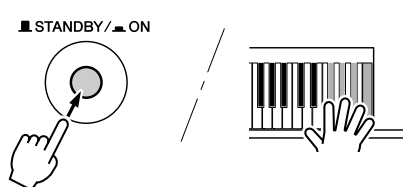

When you execute the Clear operation, User Song, User Style or User MDB you have purchased will also be cleared. Be sure to save any important data to a computer.

DATA BACKUP

To back up user data to an external device, use a USB flash memory. Refer to the following for the data you can back up using it.

- User Songs
- User Styles
- User MDB
- Registration Memory

Using USB Flash Memory

1 Connect a USB flash memory to the USB TO DEVICE terminal, being careful to insert it in the proper direction. (Do not try to force an improper connection.)

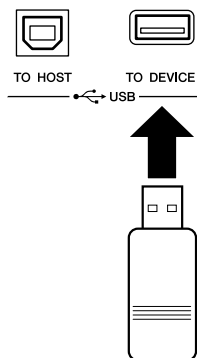

IMPORTANT

In order to play Songs or Styles copied to a USB flash memory from a computer or other device, the files must be stored either in the USB flash memory's root directory or a first, second, or third level folder. Songs stored here can be selected and played as USB Song. Songs stored in fourth-level-folders created inside a third-level folder cannot be selected and played by this instrument.

USB flash memory (Root)

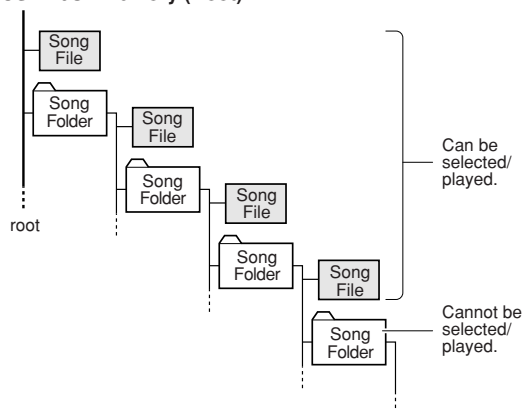

The directory can be moved using the CATEGORY [◀]/[▶] buttons.

2 Check that the “CONNECT” message is shown in the MAIN display.

NOTE

No sound will be produced if you play the keyboard while the FILE CONTROL display is showing. Also, in this state only buttons related to file functions will be active.

NOTE

The FILE CONTROL display will not appear in any of the following cases:

- During style or song playback.
- While data is being loaded from a USB flash memory.

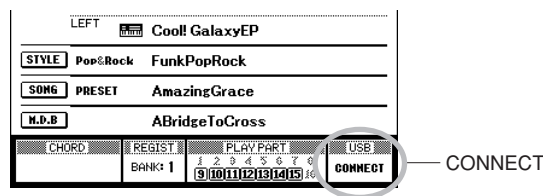

You can go to the FILE CONTROL display from which you can access USB flash memory operations by pressing the [FILE MENU] button from this display.

(Do not press this button now, but only when instructed to in the sections below.)

- Formatting USB Flash Memory
- Saving the Registration Data
- Saving a User Song or User Style
- Loading Registration Files, Style Files, Song Files or MDB Files

Formatting USB Flash Memory

A new USB flash memory device must be formatted before it can be used by this instrument.

CAUTION

- If you format a USB flash memory that already contains data, all of the data will be erased. Be careful not to erase important data when using the format function.

- 1 After connecting the USB flash memory to be formatted to the instrument's USB TO DEVICE terminal, check that the "CONNECT" message is shown in the MAIN display.

- 2 Press the [FILE MENU] button.



- 3 Use the CATEGORY [◀] and [▶] buttons to select the Format item.

The display prompts you for confirmation.

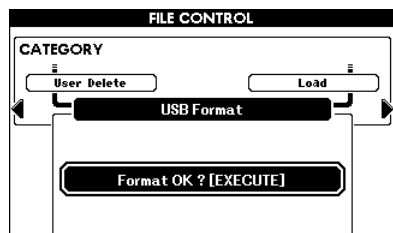
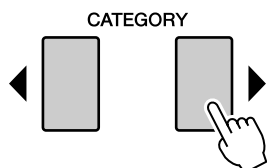

- 4 Press the [EXECUTE] button and the display prompts you for confirmation.

You can press the [-/NO] button at this point to cancel the operation.

- 5 Press the [EXECUTE] button again, or the [+ / YES] button, and the format operation will begin.

CAUTION

- Once the format-in-progress message appears in the display, the format operation cannot be canceled. Never turn off the power or remove the USB flash memory device during this operation.

- 6 A message appears in the display indicating that the operation is complete.

Press the [EXIT] button to return to the MAIN display.

NOTE

- If the USB flash memory device has been write-protected, an appropriate message will appear in the display and you will not be able to execute the operation.

Saving the Registration Data

The registration data you created in the instrument can be saved to a USB flash memory device.

- 1** Make sure that a appropriately formatted USB flash memory device has been properly connected to the instrument's USB TO DEVICE terminal, and that a "CONNECT" message is shown in the MAIN display.
- 2** Press the [FILE MENU] button.
- 3** Use the CATEGORY [◀] and [▶] buttons to locate the Regist Save item.

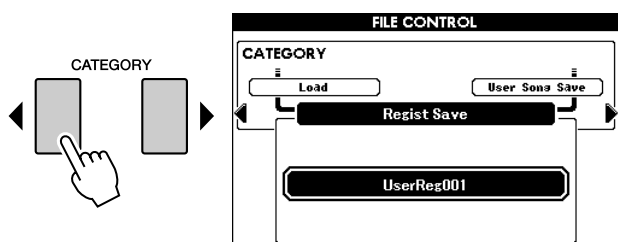

● **To Overwrite an Existing File**

If you want to overwrite a file that already exists on the USB flash memory device, use the dial or the [+ / YES] and [- / NO] buttons to select the file, then skip ahead to step 6.

NOTE

- If the USB flash memory has been write-protected, an appropriate message will appear in the display and you will not be able to execute the operation.
- If there is not enough capacity left on the USB flash memory device to save the data, an appropriate message will appear in the display and you will not be able to save the data. Erase unwanted files from the USB flash memory device to make more memory available, or use a different USB device.

- 4** Press the [EXECUTE] button. A cursor will appear below the first character in the file name.
- 5** Change the file name as necessary.
 - The [1] button moves the cursor to the left, and the [2] button moves it to the right.
 - Use the dial to select a character for the current cursor location.
 - The [8] button deletes the character at the cursor location.

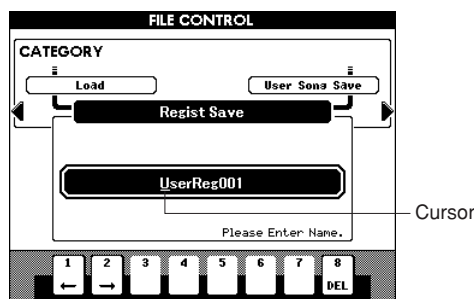
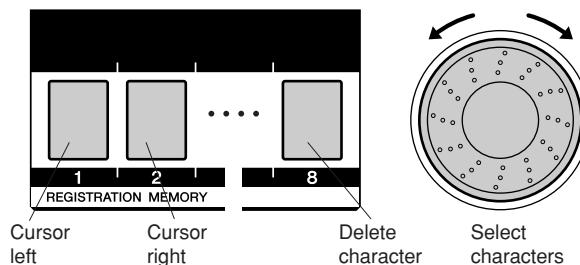

- 6** Press the [EXECUTE] button. The display prompts you for confirmation. You can cancel the save operation at this point by pressing the [- / NO] button.
- 7** Press the [EXECUTE] button again, or the [+ / YES] button, and the save operation will begin. The user song will be stored to the USER FILE folder in the USB flash memory device.

CAUTION

- Once the save-in-progress message appears in the display, the operation cannot be canceled. Never turn off the power or remove the USB flash memory device during this operation.

- 8** Press the [EXIT] button to return to the MAIN display.

NOTE

- If an existing filename is specified the display prompts you for confirmation. Press [EXECUTE] or [+ / YES] if it is OK to overwrite the file, or [- / NO] to cancel.
- The amount of time it will take to perform the save operation depends on the particular USB flash memory device you are using.

Saving a User Song or User Style

This operation saves user Songs (Song numbers 001-005) or user Styles to USB flash memory. Songs are saved in SMF Format 0.

● What is SMF (Standard MIDI File)?

The SMF (Standard MIDI File) format is one of the most common and widely compatible sequence formats used for storing sequence data. There are two variations: Format 0 and Format 1. A large number of MIDI devices are compatible with SMF Format 0, and most commercially available MIDI sequence data is provided in SMF Format 0.

- 1** Make sure that a properly formatted USB flash memory device has been properly connected to the instrument's USB TO DEVICE terminal, and that the "CONNECT" message is shown in the MAIN display.
- 2** Press the [FILE MENU] button.
- 3** Use the CATEGORY [◀] and [▶] buttons to locate the User Song or User Style Save item.
The SOURCE FILE—a user Song name or a user Style name—will be highlighted.

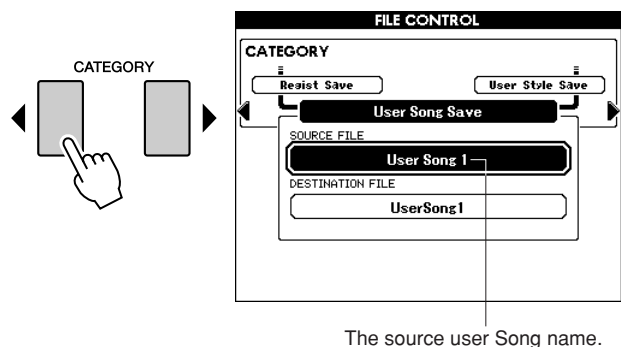

- 4** Use the dial to select the source user Song or Style.
You can press the [+ / YES] and [- / NO] buttons simultaneously to select the first user Song or Style.
- 5** Press the [EXECUTE] button.
The destination Song or Style will be highlighted, and a default name will appear for the converted Song or Style file.

● To Overwrite an Existing File

If you want to overwrite a file that already exists on the USB flash memory device, use the dial or the [+ / YES] and [- / NO] buttons to select the file, then skip ahead to step 8.

- 6** Press the [EXECUTE] button. A cursor will appear below the first character in the file name.
- 7** Change the file name as necessary. Refer to "Saving the Registration Data" for filename entry.

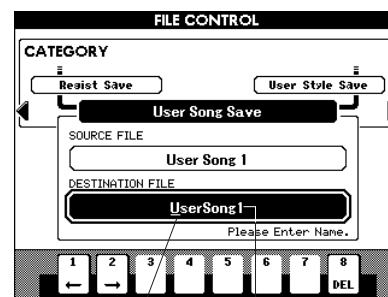

- 8** Press the [EXECUTE] button. The display prompts you for confirmation.
You can cancel the save operation at this point by pressing the [- / NO] button.
- 9** Press the [EXECUTE] button again, or the [+ / YES] button, and the save operation will begin.

The user Song will be stored to the USER FILE folder in the USB flash memory device.

⚠ CAUTION

- Once the save-in-progress message appears in the display, the operation cannot be canceled. Never turn off the power or remove the USB flash memory during this operation.

- 10** A message appears in the display indicating that the operation is complete.
Press the [EXIT] button to return to the MAIN display.

NOTE

- If an existing filename is specified, the display prompts you for confirmation. Press [EXECUTE] or [+ / YES] if it is OK to overwrite the file, or [- / NO] to cancel.
- The amount of time it will take to perform the save operation depends on the particular USB flash memory device you are using.

Loading Registration Files, Style Files, Song Files or MDB Files

Registration files, Style files, Song files and MDB files residing on a USB flash memory can be loaded to the instrument.

CAUTION

- If the same file name already exists in the instrument's internal memory, it will be overwritten.

1 With the USB flash memory device containing the file you want to load connected to the USB TO DEVICE connector, check that the "CONNECT" message is shown in the MAIN display.

2 Press the [FILE MENU] button.

3 Use the CATEGORY [◀] and [▶] buttons to locate the Load item.

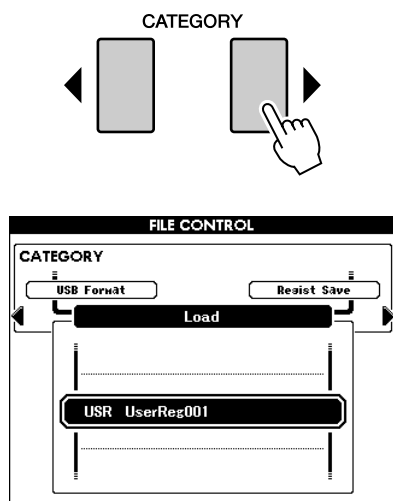

4 Use the dial to select the Registration, Style, Song or MDB file you want to load.

All user files in the USB flash memory device will be displayed first, followed by the Registration files.

NOTE

- The instrument will not recognize the Style file if it is moved out of the USER FILES folder.

5 Press the [EXECUTE] button. The display prompts you for confirmation.

You can cancel the load operation at this point by pressing the [-/NO] button.

6 Press the [EXECUTE] button again, or the [+ /YES] button, and the load operation will begin.

CAUTION

- Once the load-in-progress message appears in the display, the operation cannot be canceled. Never turn off the power or remove the USB flash memory during this operation.

7 A message appears in the display indicating that the operation is complete.

Press the [EXIT] button to return to the MAIN display

SYSTEM BOOTING FLOW CHART

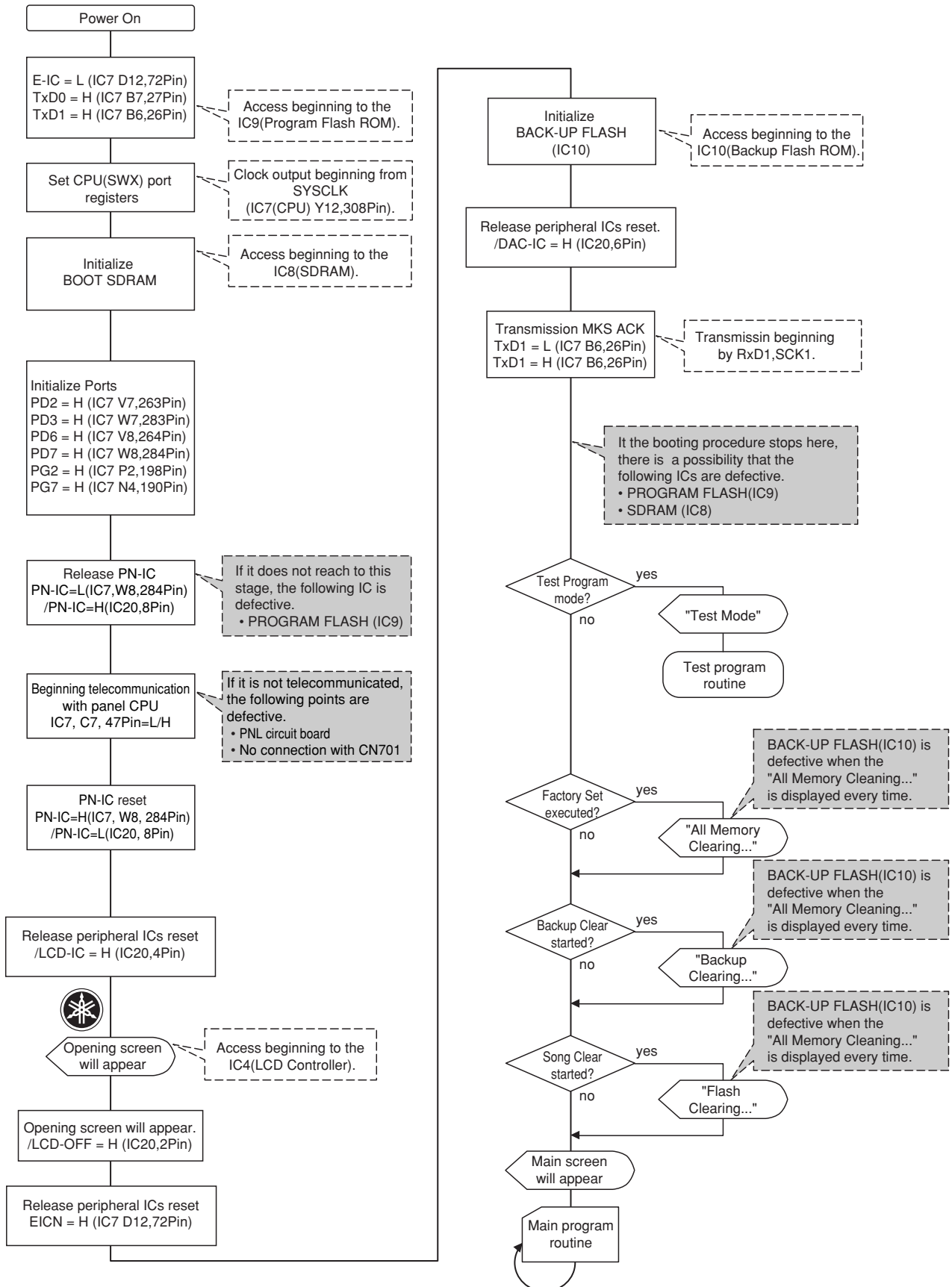

* "Factory Set" refers to the condition of turning on the power after executing "Factory Set" in the Test Program.

■ MIDI IMPLEMENTATION CHART (MIDI インプリメンテーションチャート)

YAMAHA [Digital Keyboard]

Date:11-APR-2008

Model PSR-S550 MIDI Implementation Chart

Version:1.0

Function...	Transmitted	Recognized	Remarks
Basic Default Channel Changed	1 - 16 1 - 16	1 - 16 1 - 16	
Mode Default Messages Altered	3 x *****	3 x x	
Note Number : True voice	0 - 127 *****	0 - 127 0 - 127	
Velocity Note ON Note OFF	o 9nH,v=1-127 x 9nH,v=0	o 9nH,v=1-127 x	
After Touch Key's Ch's	x x	x o	
Pitch Bend	o 0-24 semi	o 0-24 semi	
Control Change	0,32 o 1,5,7,10,11 o 6,38 o 64-67 o 71-74 o 84 o 91,93,94 o 96-97 x 98-99 o 100-101 o	o o o o o o o o o o	Bank Select Data Entry Song Controller Portament Cntrl Effect Depth RPN Inc,Dec NRPN LSB,MSB RPN LSB,MSB
Prog Change : True #	o 0 - 127 *****	o 0 - 127	
System Exclusive	o	o	
Common : Song Pos. : Song Sel. : Tune	x x x	x x x	
System : Clock Real Time: Commands	o o	o o	
Aux :All Sound OFF :Reset All Cntrls :Local ON/OFF :All Notes OFF Mes- :Active Sense sages:Reset	x x x x o x	o(120,126,127) o(121) o(122) o(123-125) o x	

Mode 1 : OMNI ON , POLY
Mode 3 : OMNI OFF, POLY

Mode 2 : OMNI ON ,MONO
Mode 4 : OMNI OFF,MONO

o : Yes
x : No

■ MIDI DATA FORMAT

NOTE:

- 1 By default (factory settings) the instrument ordinarily functions as a 16-channel multi-timbral tone generator, and incoming data does not affect the panel voices or panel settings. However, the MIDI messages listed below do affect the panel voices, auto accompaniment, and songs.
 - MIDI Master Tuning
 - System exclusive messages for changing the Reverb Type, Chorus Type and DSP Type.

- 2 Messages for these control change numbers cannot be transmitted from the instrument itself. However, they may be transmitted when playing the accompaniment, song or using the Harmony effect.
 - **<Reverb Type>** F0H, 43H, 1nH, 4CH, 02H, 01H, 00H, mmH, llH, F7H
 - mm : Reverb Type MSB
 - ll : Reverb Type LSB
 Refer to the Effect Type List (Reverbe Types) for details.
 - **<Chorus Type>** F0H, 43H, 1nH, 4CH, 02H, 01H, 20H, mmH, llH, F7H
 - mm : Chorus Type MSB
 - ll : Chorus Type LSB
 Refer to the Effect Type List (Chorus Types) for details.
 - **<DSP Type>** F0H, 43H, 1nH, 4CH, 02H, 01H, 40H, mmH, llH, F7H
 - mm : DSP Type MSB
 - ll : DSP Type LSB
 Refer to the Effect Type List (DSP Types) for details.

- 3 Exclusive
 - **<GM System ON>** F0H, 7EH, 7FH, 09H, 01H, F7H
 - This message automatically restores all default settings for the instrument, with the exception of MIDI Master Tuning.
 - **<MIDI Master Volume>** F0H, 7FH, 7FH, 04H, 01H, ll, mm, F7H
 - This message allows the volume of all channels to be changed simultaneously (Universal System Exclusive).
 - The values of "mm" is used for MIDI Master Volume. (Values for "ll" are ignored.)
 - **<XG Master Tuning>** F0H, 43H, 1nH, 4CH, 00H, 00H, 00H, ddH, ddH, ddH, F7H
 - This message simultaneously changes the tuning value of all channels.
 - The values of "dd" are used for XG Master Tuning.
 - The default value of "dd" are 00H, 04H, 00H, 00H, respectively.

- 4 When the accompaniment is started, an FAH message is transmitted. When accompaniment is stopped, an FCH message is transmitted. When the clock is set to External, both FAH (accompaniment start) and FCH (accompaniment stop) are recognized.
 - **Local ON/OFF**
 - **<Local ON>** Bn, 7A, 7F
 - **<Local OFF>** Bn, 7A, 00
 Value for "n" is ignored.

DIGITAL WORKSTATION

PSR-S550/PSR-S550B

PARTS LIST

■ CONTENTS (目次)

OVERALL ASSEMBLY (総組立)	2
UPPER CASE ASSEMBLY (上ケースAss'y)	4
KEYBOARD ASSEMBLY (16N-C61 鍵盤Ass'y).....	7
LOWER CASE ASSEMBLY (下ケースAss'y)	8
ELECTRICAL PARTS (電気部品)	10

Note) DESTINATION ABBREVIATIONS

A: Australian model	O: Chinese model
B: British model	Q: South-east Asia model
C: Canadian model	T: Taiwan model
D: German model	U: U.S.A. model
E: European model	V: General export model (110V)
F: French model	W: General export model (220V)
H: North European model	N,X: General export model
I: Indonesian model	Y: Export model
J: Japanese model	K: Korean model
M: South African model	

■ WARNING

Components having special characteristics are marked  and must be replaced with parts having specifications equal to those originally installed.

印の部品は、安全を維持するために重要な部品です。交換をする場合は、安全のため必ず指定の部品をご使用下さい。

- The numbers in "QTY" shows quantities for each unit.
- The parts with "--" in "Part No." are not available as spare parts.
- The second letter of the shaded () part number is I, not one.
- The second letter of the shaded () part number is O, not zero.
- QTY 欄に記されている数字は、各ユニット当たりの使用個数です。
- 部品 NO. が "--" の部品は、サービス用部品として準備されておりません。
- 網掛けの付いた PARTS NO. の 2 番目の文字は「イチ」ではなく「アイ」です。
- 網掛けの付いた PARTS NO. の 2 番目の文字は「ゼロ」ではなく「オー」です。

OVERALL ASSEMBLY (総組立)

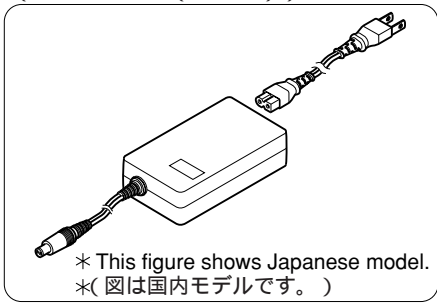
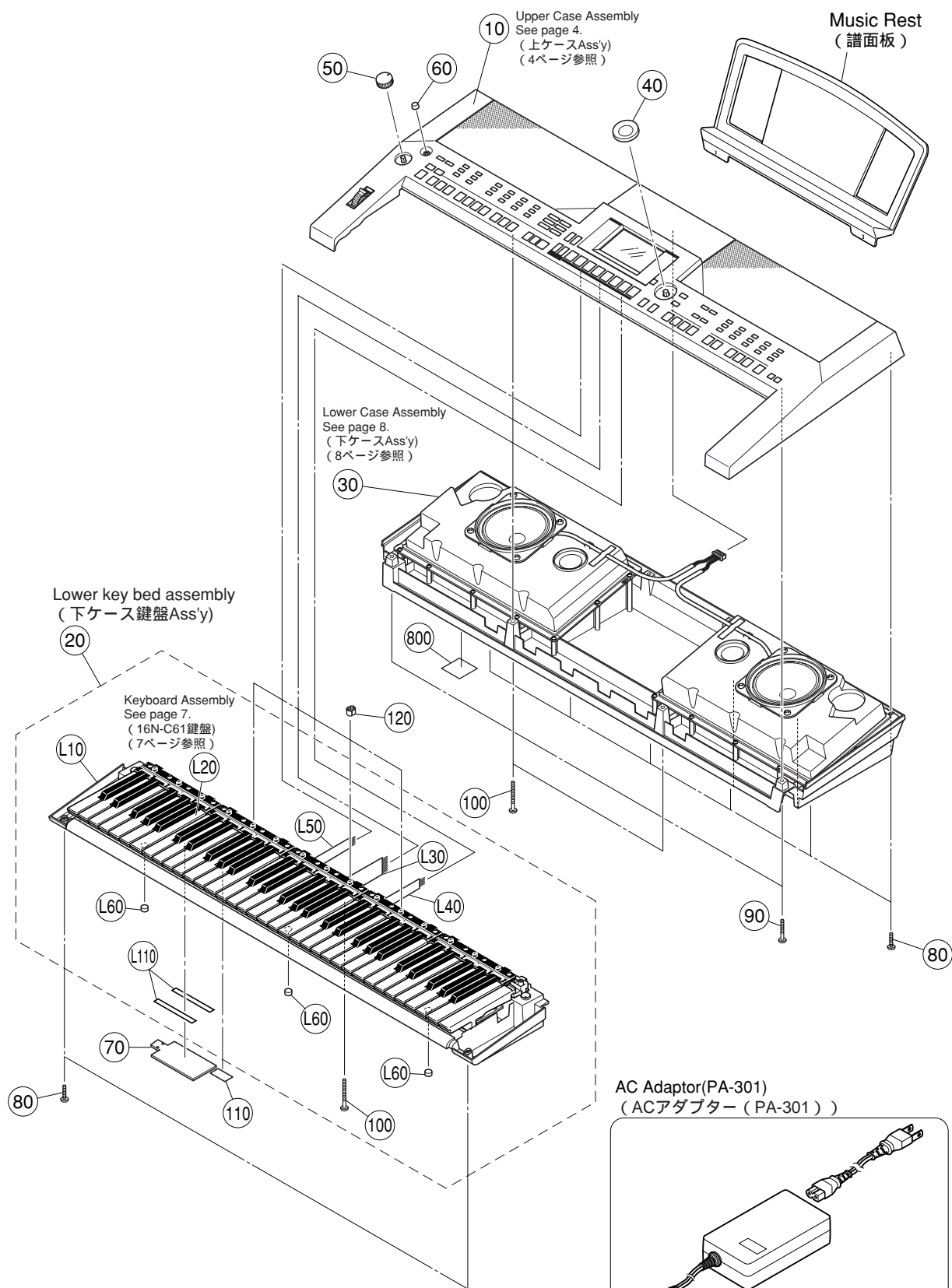

REF NO.	PART NO.	DESCRIPTION		部 品 名	REMARKS	QTY	RANK
	--	OVERALL ASSEMBLY	PT	総組立	PSR-S550/PSR-S550B		
	--	OVERALL ASSEMBLY	PT	総組立	PSR-S550 (WN54970)		
	--	OVERALL ASSEMBLY	PT	総組立	PSR-S550B (WP47710)		
	--	OVERALL ASSEMBLY	PT	総組立	PSR-S550B (WP47720)		
10	--	UPPER CASE ASSEMBLY		上ケースアッセンブリ	PSR-S550 (WN54980)		
10	--	UPPER CASE ASSEMBLY		上ケースアッセンブリ	PSR-S550B (WP47720)		
20	--	LOWER KEY BED ASSEMBLY		下ケース鍵盤アッセンブリ	(WH08860)		
30	--	LOWER CASE ASSEMBLY		下ケースアッセンブリ	(WP02260)		
40	WG455700	ENCODER KNOB	BLACK	エンコーダツマミ	DATA Dial		01
50	VU43240R	KNOB V		Vツマミ	MASTER VOLUME		
60	V715120R	PUSH KNOB BLACK		プッシュツマミ	STANDBY/ON		01
70	WH267700	BATTERY COVER		バッテリーカバー			02
80	WE98740R	BIND HEAD TAPPING SCREW-B	3.0X12 MFZN2W3	Bタイト+BIND		8	01
90	WF48930R	BIND HEAD TAPPING SCREW-B	3.0X20 MFZN2W3	Bタイト+BIND		2	01
100	WF49100R	BIND HEAD TAPPING SCREW-B	3.0X30 MFZN2W3	Bタイト+BIND		3	01
110	WH414600	DUST PROOF CLOTH	40X22X0.5	不織布			01
120	WH347400	NONWOVEN FABRIC CLOTH		不織布		3	
800	--	GOST-R LABEL	ALL COMMON E	GOST-Rマーク	PSR-S550 Y (WN00110)		
	--	LOWER KEY BED ASSEMBLY		下ケース鍵盤アッセンブリ	(WH08860)		
L10	WD83950R	LOWER CASE F		下ケース成形品(F)			08
L20	WE126700	KEYBOARD ASSEMBLY	16N C61-2M	16N-C61-2M			
L30	WE13850R	WIRING ASSEMBLY	MK1 12P L=220	M K 1 束線			01
L40	WE13870R	WIRING ASSEMBLY	MK2 5P L=250	M K 2 束線			01
L50	WE13880R	WIRING ASSEMBLY	MK3 7P L=190	M K 3 束線			01
L60	CB043752	RUBBER INSULATOR	MP-1 T1.6	ゴム		3	
L110	--	NONWOVEN FABRIC CLOTH		不織布	(WD89680)	2	
		ACCESSORIES		付属品	PSR-S550/PSR-S550B		
	WG073800	MUSIC REST		譜面板			
	X9448A00	CD-ROM MLUTI	CDROM 12cm	CD-ROMマルチ			
	WH943500	AC ADAPTER	PA-301 E	ACアダプター	E		
	WH943400	AC ADAPTER	PA-301 U	ACアダプター	U,C		12
	WH943300	AC ADAPTER	PA-301 J	ACアダプター	PSR-S550 J		
	WJ049600	AC ADAPTER	PA-301 CHN	ACアダプター	O		14
	WH943600	AC ADAPTER	PA-301 GBR	ACアダプター	B		14
	WN553300	JAPANESE SHEET SET		和文シート袋入り	PSR-S550 J		
	WN553400	CHINESE SHEET SET		中文シート袋入り	PSR-S550 O		
	WP479700	CHINESE SHEET SET		中文シート袋入り	PSR-S550B O		
	V8973600	TOOL		工具			
	WG123900	JUMPER WIRE	FVP=2.0C26SB10-400	ジャンパーワイヤー	JK-AM extension cable for service use		02
		FFC CABLE	P-70	FFCケーブル	AM-DM extension cable for service use		01

△
△
△
△
△

*
*
*

* : New Parts (新規部品)

RANK : Japan only

■ UPPER CASE ASSEMBLY (上ケース Ass'y)

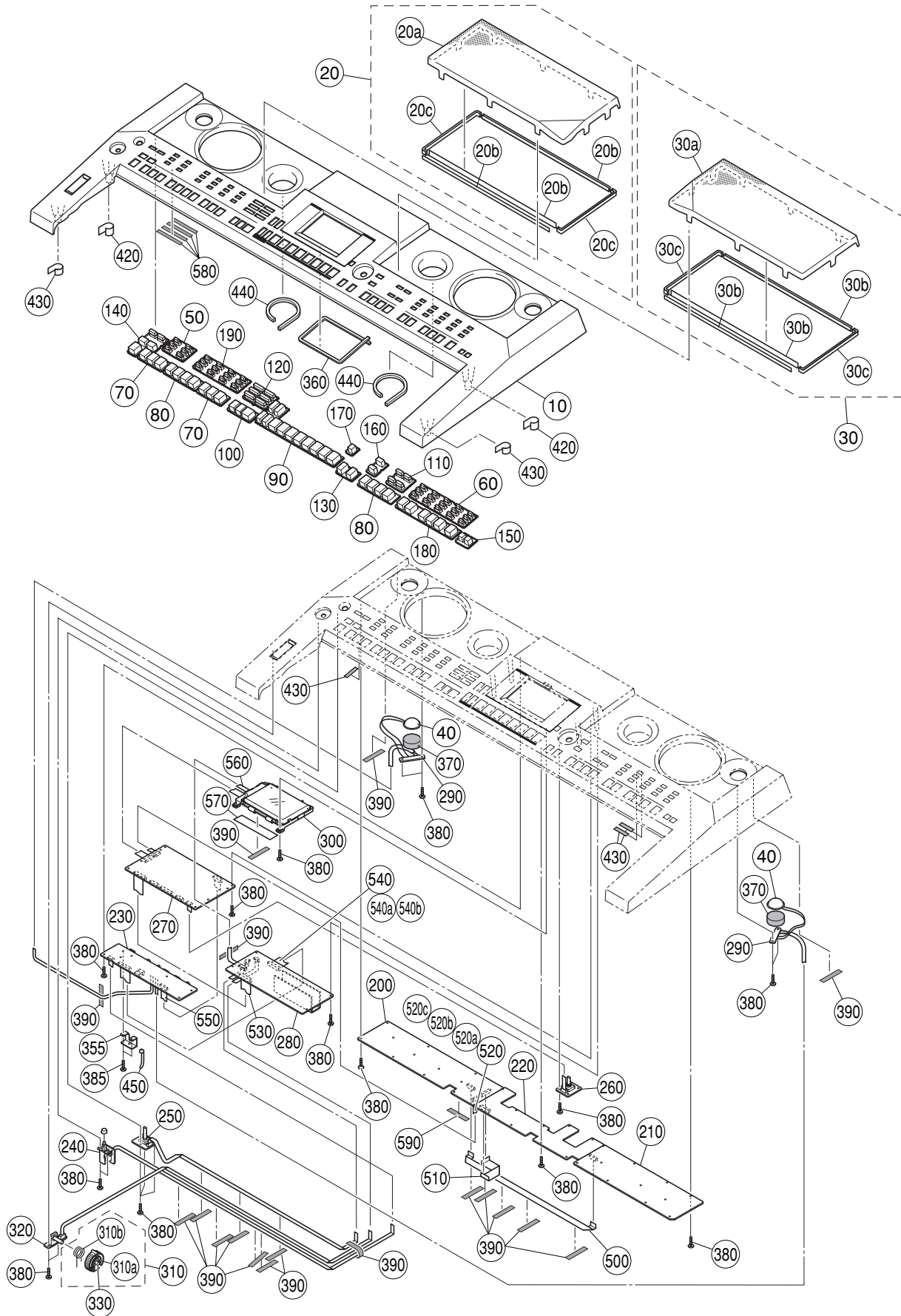

REF NO.	PART NO.	DESCRIPTION		部 品 名	REMARKS	QTY	RANK
	--	UPPER CASE ASSEMBLY		上 ケース A s s ' y	PSR-S550/PSR-S550B		
	--	UPPER CASE ASSEMBLY		上 ケース A s s ' y	PSR-S550 (WN54980)		
	--	UPPER CASE ASSEMBLY		上 ケース A s s ' y	PSR-S550B (WP47720)		
* 10	WN549900	UPPER CASE		上 ケース 塗 装 印 刷 品	PSR-S550		
* 10	WP477300	UPPER CASE		上 ケース 塗 装 印 刷 品	PSR-S550B		
* 20	WH168200	SP GRILLE L ASSEMBLY	LEFT	S P グリル L A s s ' y	PSR-S550		07
* 20	WP477600	SP GRILLE L ASSEMBLY	LEFT	S P グリル L A s s ' y	PSR-S550B		
20a	--	SP GRILLE L	LEFT	S P グリル L 塗 装 品	PSR-S550 (WH04340)		
20a	--	SP GRILLE L	LEFT	S P グリル L 塗 装 品	PSR-S550B (WP47780)		
20b	--	SP GRILL CLOTH	324X6X0.35	不 織 布 S P - G R I L	(WH28510)	3	
20c	--	SP GRILL CLOTH	120X6X0.35	不 織 布 S P - G R I L	(WH28520)	2	
30	WH168300	SP GRILLE ASSEMBLY	RIGHT	S P グリル R A s s ' y	PSR-S550		07
* 30	WP477700	SP GRILLE R ASSEMBLY	RIGHT	S P グリル R A s s ' y	PSR-S550B		
30a	--	SP GRILLE R	RIGHT	S P グリル R 塗 装 品	PSR-S550 (WH04350)		
30a	--	SP GRILLE R	RIGHT	S P グリル R 塗 装 品	PSR-S550B (WP47790)		
30b	--	SP GRILL CLOTH	324X6X0.35	不 織 布 S P - G R I L	(WH28510)	3	
30c	--	SP GRILL CLOTH	120X6X0.35	不 織 布 S P - G R I L	(WH28520)	2	
40	X0159A0R	SPEAKER(TWEETER)	3.0cm	ス ピ ー カ		2	
* 50	WN686200	PN SWITCH	X6	P N ス イ ッ チ	SONG(PRESET,SCORE,USER, LYRICS,USB,REC)		
* 60	WN686300	PN SWITCH	X15	P N ス イ ッ チ	VOICE(PIANO,GUITAR&BASS.. ...SYNTH.&FX,DRUM KIT)		
70	WH042300	PN SWITCH	X3	P N ス イ ッ チ	INTRO(I,II,III), ENDING(I,II,III)	2	02
80	WH042400	PN SWITCH	X4	P N ス イ ッ チ	MAIN BARIATION(A-D), ONE TOUCH SETTING(1-4)	2	03
* 90	WN686400	PN SWITCH	X12	P N ス イ ッ チ	REGIST/PART,MEMORY, REGIST BANK(-,+), REGISTRATION MEMORY(1-8)		
100	WH042600	PN SWITCH	X3	P N ス イ ッ チ	SYNC STOP,SYNC START, START/STOP		03
* 110	WN686600	PN SWITCH	X4	P N ス イ ッ チ	EXECUTE,MDB, FILE MENU(MENU,FUNCTION)		
* 120	WN686700	PN SWITCH	X6	P N ス イ ッ チ	TRANSPOSE(-,+),METRONOME, TAP TEMPO,TEMPO(-,+)		
* 130	WN686800	PN SWITCH	X2	P N ス イ ッ チ	CATEGORY(<,>)		
* 140	WN686900	PN SWITCH	X5	P N ス イ ッ チ	DEMO,SONG MODE,OTS LINK, AUTO FILL IN,ACMP		
* 150	WN687000	PN SWITCH	X2	P N ス イ ッ チ	UPPER OCTAVE(-,+)		
* 160	WN687100	PN SWITCH	X2	P N ス イ ッ チ	+ /YES,- /NO		
* 170	WN687200	PN SWITCH	X1	P N ス イ ッ チ	EXIT		
* 180	WH333200	PN SWITCH	X6	P N ス イ ッ チ	VOICE CONTROL(LEFT,DUAL, HARMONY,TOUCH,SUSTAIN, DSP)		03
* 190	WN687300	PN SWITCH	X12	P N ス イ ッ チ	STYLE(POP&ROCK,BALLAD,... MOVIE&SHOW,USER)		
200	WH334000	CIRCUIT BOARD	PNL	P N L シ ー ト	(X7723D0)		16
210	WH333900	CIRCUIT BOARD	PNR	P N R シ ー ト	(WH50940)(X7978B0)		16
220	WH333800	CIRCUIT BOARD	PNC	P N C シ ー ト	(WH50940)(X7978B0)		16
230	WH334200	CIRCUIT BOARD	JACK	J A C K シ ー ト	(WH33410)(X7722C0)		10
240	WH334600	CIRCUIT BOARD	PSW	P S W シ ー ト	(WH33410)(X7722C0)		06
250	WH334400	CIRCUIT BOARD	MVR	M V R シ ー ト	(WH33410)(X7722C0)		06
260	WH334500	CIRCUIT BOARD	ENC	E N C シ ー ト	(WH33410)(X7722C0)		06
* 270	WN309100	CIRCUIT BOARD	DM	D M シ ー ト	(X9574B0)		
280	WH334300	CIRCUIT BOARD	AM	A M シ ー ト	(WH33410)(X7722C0)		08
290	WH334800	CIRCUIT BOARD	TW	T W シ ー ト	(WH33410)(X7722C0)	2	06
300	WN744800	LCD UNIT	CL	液 晶 ユ ニ ッ ト			
310	VY79310R	WHEEL ASSEMBLY		ホ イ ー ル A s s ' y	PITCH BEND		04
310a	VY75080R	WHEEL		ホ イ ー ル			03
* 310a	VY75081R	WHEEL		W H E E L			
310b	VT44010R	SPRING		ホ イ ー ル パ ネ			03
320	WH334700	CIRCUIT BOARD	PB	P B シ ー ト	(WH33410)(X7722C0)		06
330	VE968501	GREASE	G-31KA (1KG)	グ レ ー ス			
* 355	WH353100	DC JACK PLATE		D C ジャ ッ ク 金 具			
360	WD697000	DUST PROOF CLOTH	PU FOAM	防 塵 フ ォ ー ム			
370	WD365700	SPONGE	27	ス ポ ン ジ		2	01
380	WE774301	BIND HEAD TAPPING SCREW-B	3.0X8 MFZN2W3	B タ イ ト + B I N D		64	
385	WE98740R	BIND HEAD TAPPING SCREW-B	3.0X12 MFZN2W3	B タ イ ト + B I N D		2	01
390	VA126101	FILAMENT TAPE	12X50	粘 着 テ ー プ		17	01
420	--	NONWOVEN FABRIC CLOTH		不 織 布	(WF25440)	2	

* : New Parts (新規部品)

RANK : Japan only

PSR-S550/PSR-S550B

REF NO.	PART NO.	DESCRIPTION		部 品 名	REMARKS	QTY	RANK
430	--	NONWOVEN FABRIC CLOTH		不 織 布	(WG81830)	5	
440	WH412900	CUSHION	150X5X5	ク ッ シ ョ ン		2	01
450	CB06925R	BINDING TIE	BK-1	インシュロックタイ			01
500	WJ465900	WIRING ASSEMBLY	FFC4	F F C 束 線 4			03
510	WJ466000	WIRING ASSEMBLY	FFC5	F F C 束 線 5			02
* 520	WQ075900	WIRING ASSEMBLY	FFC2	F F C 束 線 2			
520a	--	FERRITE CORE	HF70SH11X0.7X8	フ ェ ラ イ ト コ ア	(WP91500)		
520b	--	SPONGE		防 振 スポンジ	(WQ07570)	2	
520c	--	SPONGE		防 振 スポンジ	(WQ07580)	2	
530	WJ465800	WIRING ASSEMBLY	FFC3	F F C 束 線 3			02
540	--	WIRING ASSEMBLY	JKAM 10P	J K A M 束 線 A s s ' y	(WJ46010)		
540a	--	FERRITE CORE	K1FF26.0X9.0X5.0X1	フ ェ ラ イ ト コ ア	(WJ39420)		
540b	--	SPONGE9		防 振 スポンジ 9	(WJ46020)	2	
550	WJ465600	WIRING ASSEMBLY	FFC1	F F C 束 線 1			
560	WH336400	WIRING ASSEMBLY	LCD 2P	L C D 束 線			
570	WH219700	SPONGE		防 振 スポンジ			
580	--	NONWOVEN FABRIC CLOTH	50X4X0.35	不 織 布	(WJ30440)	4	
590	--	FILAMENT TAPE	FILAMENT 12mmX50mm	フ ィ ラ メ ン ト テ ー プ	(WG47940)		

* : New Parts (新規部品)

RANK : Japan only

■ KEYBOARD ASSEMBLY (16N-C61 鍵盤 Ass'y)

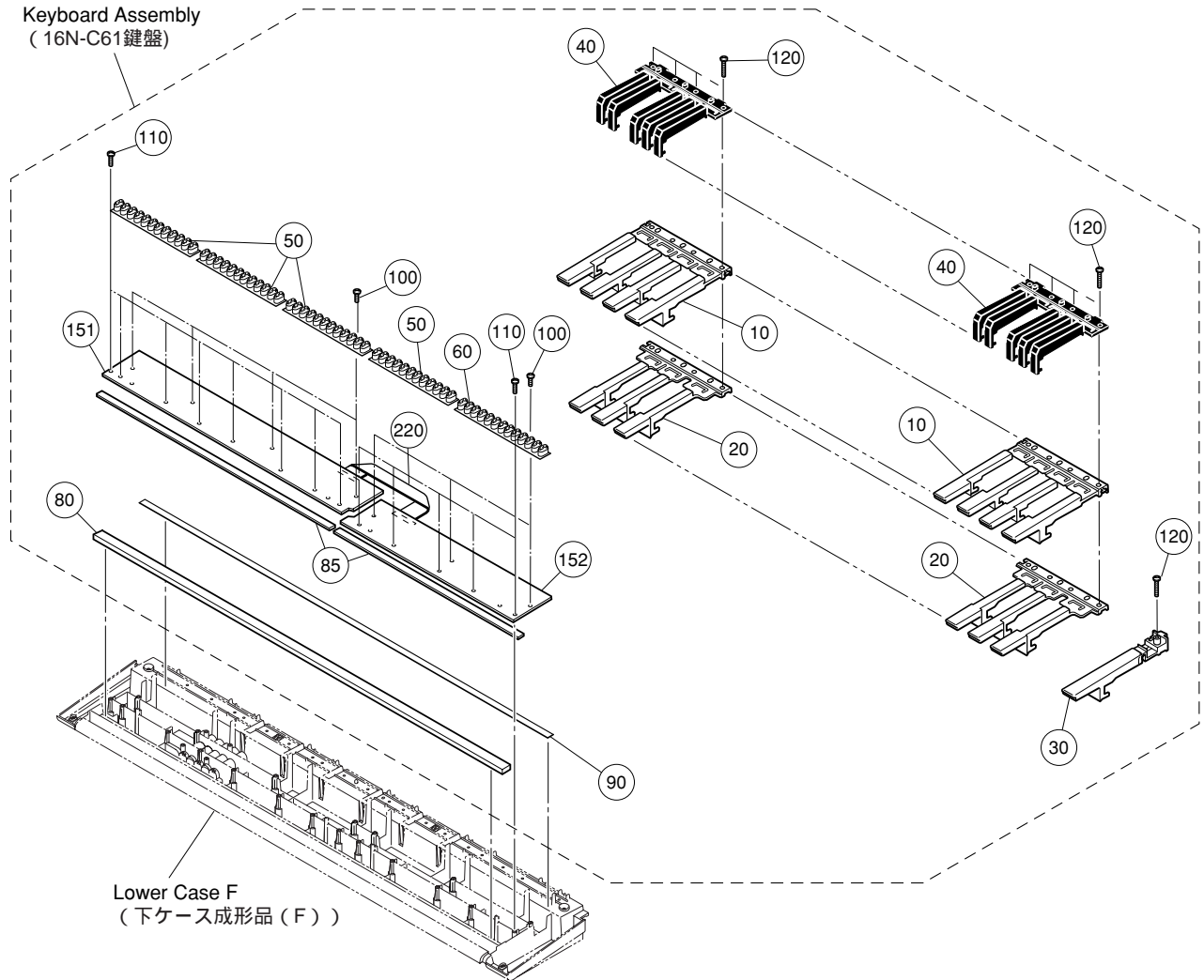

REF NO.	PART NO.	DESCRIPTION	部 品 名	REMARKS	QTY	RANK
	WE126700	KEYBOARD ASSEMBLY	1 6 N - C 6 1 鍵盤	PSR-S550/PSR-S550B		
10	V3412600	KEYBOARD ASSEMBLY	16N C61-2M	1 6 N - C 6 1 - 2 M		
10	WB12520R	WHITE KEYS	16N C,E,G,B	白 鍵 C E G B	5	
10	WB12520R	KEY CEGB	16N C,E,G,B	白 鍵 C E G B	5	
20	V3412700	WHITE KEYS	16L D,F,A	白 鍵 D F A	5	
20	WB12530R	KEY DFA	16L D,F,A	白 鍵 D F A	5	
30	V476030R	WHITE KEY 16N C'	16N C'	白 鍵 C	5	02
40	VZ27170R	BLACK KEYS	16N	黒 鍵	5	
50	V3413601	RUBBER CONTACT	16N-2M OCT 2M	接 点 ゴ ム 1 6 N 2 M	4	
60	V747740R	RUBBER CONTACT	16N2M	接 点 ゴ ム 1 6 N 2 M	4	
80	VZ303000	FELT L	3.5x11x827 WHITE	フ ェ ル ト L		
85	VZ302900	FELT U	3.0x5.0x836 WHITE	フ ェ ル ト U		
90	WA525100	CUSHION SHEET		ク ッ シ ョ ン シ ー ト		
100	WE774301	BIND HEAD TAPPING SCREW-B	3.0X8 MFZN2W3	B タ イ ト + B I N D	7	
110	WH899400	BIND HEAD TAPPING SCREW-P	3.0X12 MFZN2W3 SP	P タ イ ト + B I N D	13	01
120	WF49200R	BIND HEAD TAPPING SCREW-P	3.0X20 MFZN2W3	P タ イ ト + B I N D	21	01
151	V869530R	CIRCUIT BOARD		シ ー ト 6 1 L		(V869520)(X2336B0)
152	V869550R	CIRCUIT BOARD	61H 16N2M C61 P2	シ ー ト 6 1 H		(V869540)(X2335C0)
220	V869620R	WIRING ASSEMBLY	16N-2M-C61 L=21	中 継 束 線		

* : New Parts (新規部品)

RANK : Japan only

LOWER CASE ASSEMBLY (下ケース Ass'y)

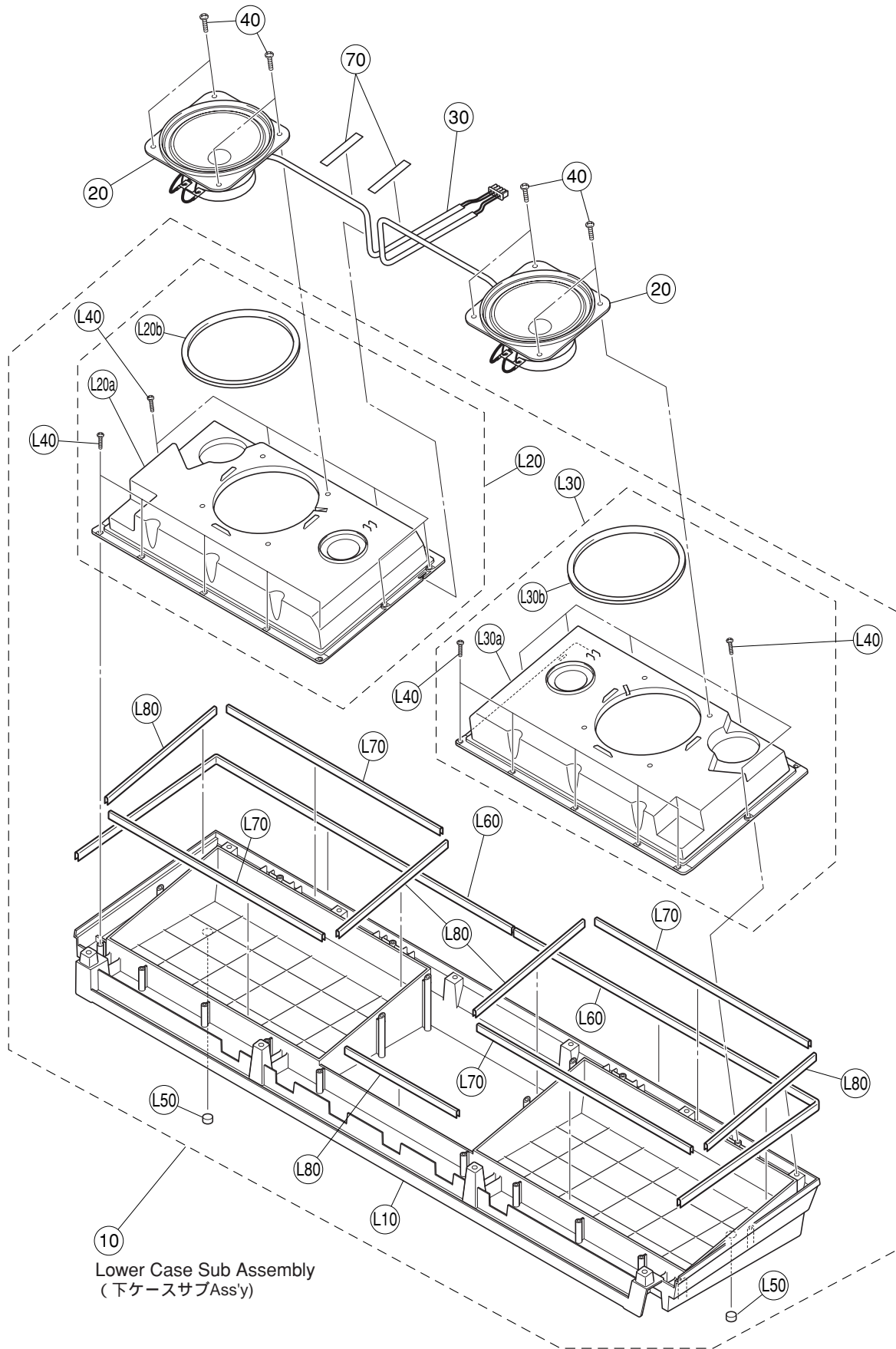

REF NO.	PART NO.	DESCRIPTION		部 品 名	REMARKS	QTY	RANK
* 10	--	LOWER CASE ASSEMBLY		下 ケース A s s ' y	PSR-S550/PSR-S550B		
	WP023100	LOWER CASE ASSEMBLY		下 ケース A s s ' y	(WP02260)		
* 20	YA372A00	LOWER CASE SUB ASSEMBLY		下 ケース サブ A s s ' y			
30	--	SPEAKER(WOOFER)	12.0cm 8 ohm 10W	ス ピ ー カ		2	
40	WE98120R	WIRING ASSEMBLY	SP	S P 束 線 A s s ' y	(WH33630)		
70	VA126101	BIND HEAD TAPPING SCREW-B	4.0X12 MFZN2W3	B タ イ ト + B I N D		8	01
		FILAMENT TAPE	12X50	粘 着 テ ー プ		2	01
* L10	WP023100	LOWER CASE SUB ASSEMBLY		下 ケース サブ A s s ' y			
L20	--	LOWER CASE R		下 ケース 成 形 品 R	(WP02320)		
L20a	--	SPEAKER BOX ASSEMBLY	LEFT	ス ピ ー カ ボ ッ ク ス L	(WH40670)		
L20b	--	SPEAKER BOX	LEFT	S P - B O X L	(WH03900)		
L30	--	SEALING TAPE SP	395X8X1	シ ー ル テ ー プ S P	(WG31740)		
L30a	--	SPEAKER BOX ASSEMBLY	RIGHT	ス ピ ー カ ボ ッ ク ス R	(WH40680)		
L30b	--	SPEAKER BOX	RIGHT	S P - B O X R	(WH03920)		
L40	WE98740R	SEALING TAPE SP	395X8X1	シ ー ル テ ー プ S P	(WG31740)		
L50	CB043752	BIND HEAD TAPPING SCREW-B	3.0X12 MFZN2W3	B タ イ ト + B I N D		20	01
L60	--	RUBBER INSULATOR	MP-1 T1.6	ゴ ム 脚		2	
L70	--	CUSHION (PE)	685X15X1	ク ッ シ ョ ン (P E)	(WJ97470)	2	
L80	--	CUSHION (PE)	332X8X1	ク ッ シ ョ ン (P E)	(WH26500)	4	
		CUSHION (PE)	176X8X1	ク ッ シ ョ ン (P E)	(WH26510)	5	

* : New Parts (新規部品)

RANK : Japan only

■ ELECTRICAL PARTS (電気部品)

AM,ENC,JACK,MVR,PB,PSW,TW

REF NO.	PART NO.	DESCRIPTION	部 品 名	REMARKS	QTY	RANK
		ELECTRICAL PARTS	電 気 部 品	PSR-S550/PSR-S550B		
	WH334300	CIRCUIT BOARD	A M シ - ト	(WH33410)(X7722C0)		08
	WH334500	CIRCUIT BOARD	E N C シ - ト	(WH33410)(X7722C0)		06
	WH334200	CIRCUIT BOARD	J A C K シ - ト	(WH33410)(X7722C0)		10
	WH334400	CIRCUIT BOARD	M V R シ - ト	(WH33410)(X7722C0)		06
	WH334700	CIRCUIT BOARD	P B シ - ト	(WH33410)(X7722C0)		06
	WH334600	CIRCUIT BOARD	P S W シ - ト	(WH33410)(X7722C0)		06
	WH334800	CIRCUIT BOARD	T W シ - ト	(WH33410)(X7722C0)		06
	WN309100	CIRCUIT BOARD	D M シ - ト	(X9574B0)		
	WH334000	CIRCUIT BOARD	P N L シ - ト	(X7723D0)		16
	WH333800	CIRCUIT BOARD	P N C シ - ト	(WH50940)(X7978B0)		16
	WH333900	CIRCUIT BOARD	P N R シ - ト	(WH50940)(X7978B0)		16
	V869530R	CIRCUIT BOARD	シ - ト 6 1 L	(V869520)(X2336B0)		
	V869550R	CIRCUIT BOARD	シ - ト 6 1 H	(V869540)(X2335C0)		06
	WH334300	CIRCUIT BOARD	A M シ - ト	(WH33410)(X7722C0)		08
	WH334500	CIRCUIT BOARD	E N C シ - ト	(WH33410)(X7722C0)		06
	WH334200	CIRCUIT BOARD	J A C K シ - ト	(WH33410)(X7722C0)		10
	WH334400	CIRCUIT BOARD	M V R シ - ト	(WH33410)(X7722C0)		06
	WH334700	CIRCUIT BOARD	P B シ - ト	(WH33410)(X7722C0)		06
	WH334600	CIRCUIT BOARD	P S W シ - ト	(WH33410)(X7722C0)		06
	WH334800	CIRCUIT BOARD	T W シ - ト	(WH33410)(X7722C0)		06
	--	JUMPER CABLE	0.55 TIN	ジ ャ ン パ - 線	(VA07890)	22
10	WE98740R	BIND HEAD TAPPING SCREW-B	3.0X12 MFZN2W3	B タイ ト + B I N D		2
20	--	SILICON GREASE	G-746	シ リ コ ン グ リ ス	(0412125)	01
20	--	SILICON GREASE	X-113A G746	シ リ コ ン グ リ ス	(VA79810)	
C103	V3773100	ELECTROLYTIC CAPACITOR	4700.0 25.0V FORM.	ケ ミ コ ン		
C103	VK373000	ELECTROLYTIC CAPACITOR	4700 25.0V	ケ ミ コ ン		03
C104	V3324600	ELECTROLYTIC CAPACITOR	220.00 25.0V RX TP	ケ ミ コ ン		
C105	UR867100	ELECTROLYTIC CAPACITOR	10.00 50.0V RX TP	ケ ミ コ ン		
C105	V3512300	ELECTROLYTIC CAPACITOR	10.00 50.0V TP	ケ ミ コ ン		
C106	VC69480R	CEAMIC CAPACITOR	0.1000 25V Z T	半 導 体 セ ラ コ ン		01
C106	VM902400	SEMICONDUCTIVE CERA. CAP.	0.1000 25V Z FORM.	半 導 体 セ ラ コ ン 天 津		01
-109	VC69480R	CEAMIC CAPACITOR	0.1000 25V Z T	半 導 体 セ ラ コ ン		01
-109	VM902400	SEMICONDUCTIVE CERA. CAP.	0.1000 25V Z FORM.	半 導 体 セ ラ コ ン 天 津		01
C110	V3324600	ELECTROLYTIC CAPACITOR	220.00 25.0V RX TP	ケ ミ コ ン		
C111	V3324600	ELECTROLYTIC CAPACITOR	220.00 25.0V RX TP	ケ ミ コ ン		
C201	UA35310R	POLYESTER FILM CAPACITOR	1000P 50V J RX TP	マ イ ラ - コ ン		01
C202	UA35310R	POLYESTER FILM CAPACITOR	1000P 50V J RX TP	マ イ ラ - コ ン		01
C201	UA653100	POLYESTER FILM CAPACITOR	1000P 50V J RX TP	マ イ ラ - コ ン		
C202	UA653100	POLYESTER FILM CAPACITOR	1000P 50V J RX TP	マ イ ラ - コ ン		
C203	UA355150	POLYESTER FILM CAPACITOR	0.1500 50V J RX TP	マ イ ラ - コ ン		
C204	UA355150	POLYESTER FILM CAPACITOR	0.1500 50V J RX TP	マ イ ラ - コ ン		
C203	V551560R	MYLAR CAPACITOR	0.1500 50V J	マ イ ラ - コ ン		
C204	V551560R	MYLAR CAPACITOR	0.1500 50V J	マ イ ラ - コ ン		
C203	VR168500	POLYESTER MULTLAY CAP.	ECQ-V1H154JL3	積 層 マ イ ラ - コ ン		
C204	VR168500	POLYESTER MULTLAY CAP.	ECQ-V1H154JL3	積 層 マ イ ラ - コ ン		
C205	UA352470	POLYESTER FILM CAPACITOR	470P 50V J RX TP	マ イ ラ - コ ン		01
C206	UA352470	POLYESTER FILM CAPACITOR	470P 50V J RX TP	マ イ ラ - コ ン		01
C205	UA652470	POLYESTER FILM CAPACITOR	470P 50V J RX TP	マ イ ラ - コ ン		
C206	UA652470	POLYESTER FILM CAPACITOR	470P 50V J RX TP	マ イ ラ - コ ン		
C207	UR838100	ELECTROLYTIC CAPACITOR	100.00 16.0V RX TP	ケ ミ コ ン		
C208	UR838100	ELECTROLYTIC CAPACITOR	100.00 16.0V RX TP	ケ ミ コ ン		
C207	V350850R	ELECTROLYTIC CAPACITOR	100.00 16.0V TP	ケ ミ コ ン		
C208	V350850R	ELECTROLYTIC CAPACITOR	100.00 16.0V TP	ケ ミ コ ン		
C209	UR867100	ELECTROLYTIC CAPACITOR	10.00 50.0V RX TP	ケ ミ コ ン		
C209	V3512300	ELECTROLYTIC CAPACITOR	10.00 50.0V TP	ケ ミ コ ン		
C210	VC69480R	CEAMIC CAPACITOR	0.1000 25V Z T	半 導 体 セ ラ コ ン		01
C210	VM902400	SEMICONDUCTIVE CERA. CAP.	0.1000 25V Z FORM.	半 導 体 セ ラ コ ン 天 津		01
C211	UR848470	ELECTROLYTIC CAPACITOR	470.00 25.0V RX TP	ケ ミ コ ン		
C211	V351000R	ELECTROLYTIC CAPACITOR	470.00 25.0V TP	ケ ミ コ ン		
C212	UA355100	POLYESTER FILM CAPACITOR	0.1000 50V J RX TP	マ イ ラ - コ ン		
C212	V5515400	MYLAR CAPACITOR	0.1000 50V J	マ イ ラ - コ ン		
C212	VR168300	POLYESTER MULTLAY CAP.	ECQ-V1H104JL3	積 層 マ イ ラ - コ ン		
-215	UA355100	POLYESTER FILM CAPACITOR	0.1000 50V J RX TP	マ イ ラ - コ ン		
-215	V5515400	MYLAR CAPACITOR	0.1000 50V J	マ イ ラ - コ ン		
-215	VR168300	POLYESTER MULTLAY CAP.	ECQ-V1H104JL3	積 層 マ イ ラ - コ ン		
C216	VC69480R	CEAMIC CAPACITOR	0.1000 25V Z T	半 導 体 セ ラ コ ン		01
C216	VM902400	SEMICONDUCTIVE CERA. CAP.	0.1000 25V Z FORM.	半 導 体 セ ラ コ ン 天 津		01
C217	UA352470	POLYESTER FILM CAPACITOR	470P 50V J RX TP	マ イ ラ - コ ン		01

* : New Parts (新規部品)

RANK : Japan only

AM,ENC,JACK,MVR,PB,PSW,TW

REF NO.	PART NO.	DESCRIPTION	部 品 名	REMARKS	QTY	RANK
C217	UA652470	POLYESTER FILM CAPACITOR	470P 50V J RX TP	マイラ - コン		
C401	VC69480R	CEAMIC CAPACITOR	0.1000 25V Z T	半 導 体 セラコン		01
C401	VM902400	SEMICONDUCTIVE CERA. CAP.	0.1000 25V Z FORM.	半 導 体セラコン 天津		01
C451	UA354470	POLYESTER FILM CAPACITOR	0.0470 50V J RX TP	マイラ - コン		
C452	UA354470	POLYESTER FILM CAPACITOR	0.0470 50V J RX TP	マイラ - コン		
C451	UA654470	POLYESTER FILM CAPACITOR	0.0470 50V J RX TP	マイラ - コン		
C452	UA654470	POLYESTER FILM CAPACITOR	0.0470 50V J RX TP	マイラ - コン		
C451	VS884200	MYLAR CAPACITOR	0.0470 100V K TE	マイラ - コン		
C452	VS884200	MYLAR CAPACITOR	0.0470 100V K TE	マイラ - コン		
C453	UR837330	ELECTROLYTIC CAPACITOR	33.00 16.0V RX TP	ケ ミ コ ン		
C454	UR837330	ELECTROLYTIC CAPACITOR	33.00 16.0V RX TP	ケ ミ コ ン		
C453	V3508300	ELECTROLYTIC CAPACITOR	33.00 16.0V TP	ケ ミ コ ン		
C454	V3508300	ELECTROLYTIC CAPACITOR	33.00 16.0V TP	ケ ミ コ ン		
C455	VR025400	CERAMIC CAPACITOR-2B	220P 63V K FORMING	セラコン 2 B 天津製		
C456	VR025400	CERAMIC CAPACITOR-2B	220P 63V K FORMING	セラコン 2 B 天津製		
CN101	VF728200	CONNECTOR BASE PIN	52147 10P TE	ワイヤートラップ		
CN102	VK024600	CONNECTOR BASE PIN	52147 2P TE	ワイヤートラップ		
CN103	VK024700	CONNECTOR BASE PIN	52147 3P TE	ワイヤートラップ		
CN104	WC33890R	FFC CONNECTOR	52806 27P TE	FFCコネクタ		
CN204	VK024900	CONNECTOR BASE PIN	52147 5P TE	ワイヤートラップ		
CN301	VI878100	BASE PIN	51048 3P TE	ケーブルホルダー		
CN301	VZ34160R	CABLE HOLDER	51048 3P TE	ケーブルホルダー天津		
CN310	VI878300	BASE PIN	51048 5P TE	ケーブルホルダー		
CN310	VZ34170R	CABLE HOLDER	51048 5P TE	ケーブルホルダー天津		
CN320	VI878100	BASE PIN	51048 3P TE	ケーブルホルダー		
CN320	VZ34160R	CABLE HOLDER	51048 3P TE	ケーブルホルダー天津		
CN330	VI878200	BASE PIN	51048 4P TE	ケーブルホルダー		
CN330	VY668400	CABLE HOLDER	51048 4P TE	ケーブルホルダー天津		
CN401	WA245700	USB CONNECTOR	YKF45 4P SE	U S B コネクタ		02
CN401	WH382500	USB CONNECTOR	UAR27 4P SE	U S B コネクタ	USB TO DEVICE	
CN401	* WQ353300	USB CONNECTOR	4P SE	U S B コネクタ		
CN402	V6802600	USB JACK	USB 4P SE	U S B ジャック	USB TO HOST	02
CN402	V901600R	USB CONNECTOR	YKF45-0021N 4P SE	U S B コネクタ B		
CN403	VV678400	FFC CONNECTOR	52806 14P TE	FFCコネクタ		01
CN451	VF728200	CONNECTOR BASE PIN	52147 10P TE	ワイヤートラップ		
CN452	VK024800	CONNECTOR BASE PIN	52147 4P TE	ワイヤートラップ		
CN453	LB918040	BASE PIN I-TYPE	XH 4P TE	ベ ス ツ キ ポ ス ト		
CN454	VI878000	BASE PIN	51048 2P TE	ケーブルホルダー		
CN455	VI878000	BASE PIN	51048 2P TE	ケーブルホルダー		
CN454	VY66830R	CABLE HOLDER	51048 2P TE	ケーブルホルダー天津		
CN455	VY66830R	CABLE HOLDER	51048 2P TE	ケーブルホルダー天津		
D102	WG084500	DIODE	RJ43 FORMING	ショットキーダイオード		01
D451	V860310R	DIODE	2A02G-01 X0 JI	ダ イ オ ー ド		
D451	VV73140R	DIODE	2A02-05 X0	ダ イ オ ー ド		01
EC301	VU48130R	ENCODER	REB161(9X5)PVB15FH	1 6 形 エ ン コ ー ダ	DATA Dial	03
IC101	X0548A00	IC	SI-8050S	I C	DC-DC CONVERTER	
IC102	X5887A0R	IC	BA50BC0T +5V 1.0A	I C	REGULATOR +5V 1.0A	03
IC201	XY209A0R	IC	LA4625-E 13.5W	I C	REGULATOR 13.5W	05
JK401	VC68750R	PHONE JACK, BL	JACK YKB21-5014	ホ ー ン コ ネ ク タ (黒)	SUSTAIN	01
JK401	WE24520R	PHONE JACK	JY-6314-01-020	ホ ー ン コ ネ ク タ (黒)		
JK451	LB101870	HEADPHONE JACK	JACK YKB21-5006	ホ ー ン コ ネ ク タ	PHONES/OUTPUT	03
JK451	VV943300	PHONE JACK	HTJ064-04A	ホ ー ン コ ネ ク タ		02
JK452	V9613600	CONNECTOR	HEC0740-010618	電 源 コ ネ ク タ	DC IN 16V	02
K101	--	HEAT SINK		放 熱 板	(WH74610)	
L101	VZ01790R	COIL	HP-022J 180U	コ イ ル		05
L101	WF687800	COIL	ER-045005B	コ イ ル		04
L101	WF688300	COIL	TBC-181M-3A-8026B	コ イ ル		
L102	VB835000	COIL	20uH FL05RD200AT	コ イ ル 2 0 U		01
L102	VT27920R	COIL	DX001-20UH	コイル 20U 天津		
L203	GE300670	FERRIT BEAD	BL02RN2R1P1A T	フェライトビーズ		02
-206	GE300670	FERRIT BEAD	BL02RN2R1P1A T	フェライトビーズ		02
L402	GE300670	FERRIT BEAD	BL02RN2R1P1A T	フェライトビーズ		02
L403	VB835000	COIL	20uH FL05RD200AT	コ イ ル 2 0 U		01
L403	VT27920R	COIL	DX001-20UH	コイル 20U 天津		
L405	VB835000	COIL	20uH FL05RD200AT	コ イ ル 2 0 U		01
L406	VB835000	COIL	20uH FL05RD200AT	コ イ ル 2 0 U		01
L405	VT27920R	COIL	DX001-20UH	コイル 20U 天津		
L406	VT27920R	COIL	DX001-20UH	コイル 20U 天津		
L451	V679560R	LINE FILTER	BDL40-01	ラ イ ン フ ィ ル タ ー		
L451	VQ88400R	COIL	CM08RB01 RX	ラ イ ン フ ィ ル タ ー		03

*: New Parts (新規部品)

RANK : Japan only

AM,ENC,JACK,MVR,PB,PSW,TW,DM

REF NO.	PART NO.	DESCRIPTION	部 品 名	REMARKS	QTY	RANK
L452	VB835000	COIL	20uH FL05RD200AT	コイル 20U		01
L453	VB835000	COIL	20uH FL05RD200AT	コイル 20U		01
L452	VT27920R	COIL	DX001-20UH	コイル 20U 天津		
L453	VT27920R	COIL	DX001-20UH	コイル 20U 天津		
R101	HF45510R	CARBON RESISTOR 1/4	100.0 1/4 J AX TP	カーボン抵抗		01
R101	V254800R	CARBON RESISTOR 1/6	100.0 1/6J 26TP	カーボン抵抗		
-104	HF45510R	CARBON RESISTOR 1/4	100.0 1/4 J AX TP	カーボン抵抗		01
-104	V254800R	CARBON RESISTOR 1/6	100.0 1/6J 26TP	カーボン抵抗		
R201	HF456390	CARBON RESISTOR 1/4	3.9K 1/4 J AX TP	カーボン抵抗		
R202	HF456390	CARBON RESISTOR 1/4	3.9K 1/4 J AX TP	カーボン抵抗		
R201	V2549900	CARBON RESISTOR 1/6	3.9K 1/6 J 26TP	カーボン抵抗		
R202	V2549900	CARBON RESISTOR 1/6	3.9K 1/6 J 26TP	カーボン抵抗		
R203	HF457150	CARBON RESISTOR 1/4	15.0K 1/4 J AX TP	カーボン抵抗		01
R204	HF457150	CARBON RESISTOR 1/4	15.0K 1/4 J AX TP	カーボン抵抗		01
R203	V255060R	CARBON RESISTOR 1/6	15.0K 1/6J 26TP	カーボン抵抗		
R204	V255060R	CARBON RESISTOR 1/6	15.0K 1/6J 26TP	カーボン抵抗		
R205	HF45727R	CARBON RESISTOR 1/4	27.0K 1/4 J AX TP	カーボン抵抗		01
R205	V2550900	CARBON RESISTOR 1/6	27.0K 1/6J 26TP	カーボン抵抗		
R206	WD55670R	FLAME PROOF CARBON RES.	2.2 1/4 J TE-26	不燃化カーボン抵抗		01
-209	WD55670R	FLAME PROOF CARBON RES.	2.2 1/4 J TE-26	不燃化カーボン抵抗		01
R210	HF456470	CARBON RESISTOR 1/4	4.7K 1/4 J AX TP	カーボン抵抗		01
R211	HF456470	CARBON RESISTOR 1/4	4.7K 1/4 J AX TP	カーボン抵抗		01
R210	V255000R	CARBON RESISTOR 1/6	4.7K 1/6 J 26TP	カーボン抵抗		
R211	V255000R	CARBON RESISTOR 1/6	4.7K 1/6 J 26TP	カーボン抵抗		
R401	HF456180	CARBON RESISTOR 1/4	1.8K 1/4 J AX TP	カーボン抵抗		
R401	V2549500	CARBON RESISTOR 1/6	1.8K 1/6 J 26TP	カーボン抵抗		
R402	HF457330	CARBON RESISTOR 1/4	33.0K 1/4 J AX TP	カーボン抵抗		
R402	V2551000	CARBON RESISTOR 1/6	33.0K 1/6J 26TP	カーボン抵抗		
R403	HF456470	CARBON RESISTOR 1/4	4.7K 1/4 J AX TP	カーボン抵抗		01
R403	V255000R	CARBON RESISTOR 1/6	4.7K 1/6 J 26TP	カーボン抵抗		
R451	HF45510R	CARBON RESISTOR 1/4	100.0 1/4 J AX TP	カーボン抵抗		01
R452	HF45510R	CARBON RESISTOR 1/4	100.0 1/4 J AX TP	カーボン抵抗		01
R451	V254800R	CARBON RESISTOR 1/6	100.0 1/6J 26TP	カーボン抵抗		
R452	V254800R	CARBON RESISTOR 1/6	100.0 1/6J 26TP	カーボン抵抗		
R453	HF45433R	CARBON RESISTOR 1/4	33.0 1/4 J AX TP	カーボン抵抗		01
R454	HF45433R	CARBON RESISTOR 1/4	33.0 1/4 J AX TP	カーボン抵抗		01
R453	V2547400	CARBON RESISTOR 1/6	33.0 1/6J 26TP	カーボン抵抗		
R454	V2547400	CARBON RESISTOR 1/6	33.0 1/6J 26TP	カーボン抵抗		
SW330	V966170R	PUSH SWITCH	SY16-32-4(U99S2)/T	プッシュスイッチ	STANDBY/ON	03
SW330	VY98040R	PUSH SWITCH	SDDL15700 J.UC.CE	プッシュスイッチ		03
TH451	V8132800	MULTI FUSE MF-R185-2 1.85A	MF-R185-AP	マルチヒューズ		02
TH451	VU847300	PROTECTOR SWITCH	RUEF185 1.85A 30V	ポリスイッチ		
TR401	WH336700	TRANSISTOR	2SC2062STP 10000 T	トランジスタ 2SC		
VR310	WC70980R	ROTARY VARIABLE RESISTOR	A 5.0K XV014111YGP	二連ロータリーVR	MASTER VOLUME	
VR320	VZ48630R	ROTARY VARIABLE RESISTOR	B10K EVJ05DF20B14	ロータリーVR	PITCH BEND	
VR401	VV04910R	ROTARY VARIABLE RESISTOR	B 10K RK09K1110	ロータリーVR	CONTRAST	01
WH401	--	WIRING ASSEMBLY	GND	G N D 束線	(WJ45910)	
WH301	--	WIRING ASSEMBLY	ENC 3P	E N C 束線	(WH33510)	
WH310	--	WIRING ASSEMBLY	MVR 5P	M V R 束線	(WH33500)	
WH320	--	WIRING ASSEMBLY	PB 3P	P B 束線	(WH33530)	
WH330	--	WIRING ASSEMBLY	PSW 4P	P S W 束線	(WH33520)	
WH454	--	WIRING ASSEMBLY	TWL 2P	T W L 束線	(WH33620)	
WH455	--	WIRING ASSEMBLY	TWL 2P	T W L 束線	(WH33620)	
*	WN309100	CIRCUIT BOARD	DM	D M シート	(X9574B0)	
C1	US14510R	CERAMIC CAPACITOR-F (CHIP)	0.1000 25V Z RECT.	チップセラ (F)		01
C2	US14510R	CERAMIC CAPACITOR-F (CHIP)	0.1000 25V Z RECT.	チップセラ (F)		01
C3	UF03747R	ELECTROLYTIC CAPACITOR	47 16V	チップケミコン		
C22	US14510R	CERAMIC CAPACITOR-F (CHIP)	0.1000 25V Z RECT.	チップセラ (F)		01
-29	US14510R	CERAMIC CAPACITOR-F (CHIP)	0.1000 25V Z RECT.	チップセラ (F)		01
C30	WG888300	MULTILAYER CERAMIC CAP.	10.0 6.3V K TP	チップ積層セラコン		
C31	US14510R	CERAMIC CAPACITOR-F (CHIP)	0.1000 25V Z RECT.	チップセラ (F)		01
C32	US062220	CERAMIC CAPACITOR-SL CHIP	220P 50V J RECT.	チップセラ (S L)		
-35	US062220	CERAMIC CAPACITOR-SL CHIP	220P 50V J RECT.	チップセラ (S L)		
C36	US063100	CERAMIC CAPACITOR-B (CHIP)	1000P 50V K RECT.	チップセラ (B)		
C37	US062100	CERAMIC CAPACITOR-SL CHIP	100P 50V J RECT.	チップセラ (S L)		
-40	US062100	CERAMIC CAPACITOR-SL CHIP	100P 50V J RECT.	チップセラ (S L)		
C41	US063100	CERAMIC CAPACITOR-B (CHIP)	1000P 50V K RECT.	チップセラ (B)		
C43	WG251600	CHIP CERAMIC CAPACITOR	4.7 6.3V K RECT.	チップセラ		01
C44	US14510R	CERAMIC CAPACITOR-F (CHIP)	0.1000 25V Z RECT.	チップセラ (F)		01

* : New Parts (新規部品)

RANK : Japan only

DM

REF NO.	PART NO.	DESCRIPTION		部 品 名	REMARKS	QTY	RANK
C45	US062100	CERAMIC CAPACITOR-SL CHIP	100P 50V J RECT.	チップセラ (S L)			
C46	WG251600	CHIP CERAMIC CAPACITOR	4.7 6.3V K RECT.	チップセラ			01
C47	US061220	CERAMIC CAPACITOR-CH CHIP	22P 50V J RECT.	チップセラ (C H)			
C48	US061220	CERAMIC CAPACITOR-CH CHIP	22P 50V J RECT.	チップセラ (C H)			
C49	WG251600	CHIP CERAMIC CAPACITOR	4.7 6.3V K RECT.	チップセラ			01
C51	US063100	CERAMIC CAPACITOR-B (CHIP)	1000P 50V K RECT.	チップセラ (B)			
C52	US064100	CERAMIC CAPACITOR-B (CHIP)	0.0100 50V K RECT.	チップセラ (B)			
-57	US064100	CERAMIC CAPACITOR-B (CHIP)	0.0100 50V K RECT.	チップセラ (B)			
C58	WG888300	MULTILAYER CERAMIC CAP.	10.0 6.3V K TP	チップ積層セラコン			
C59	US064100	CERAMIC CAPACITOR-B (CHIP)	0.0100 50V K RECT.	チップセラ (B)			
-95	US064100	CERAMIC CAPACITOR-B (CHIP)	0.0100 50V K RECT.	チップセラ (B)			
C96	WG888300	MULTILAYER CERAMIC CAP.	10.0 6.3V K TP	チップ積層セラコン			
C97	WG888300	MULTILAYER CERAMIC CAP.	10.0 6.3V K TP	チップ積層セラコン			
C98	WG251600	CERAMIC CAPACITOR	4.7 6.3V K RECT.	チップセラ チップセラ			01
C99	US064100	CERAMIC CAPACITOR-B (CHIP)	0.0100 50V K RECT.	(B)			
C100	US064100	CERAMIC CAPACITOR-B (CHIP)	0.0100 50V K RECT.	チップセラ (B)			
C101	US062470	CERAMIC CAPACITOR-SL CHIP	470P 50V J RECT.	チップセラ (S L)			
C102	US064100	CERAMIC CAPACITOR-B (CHIP)	0.0100 50V K RECT.	チップセラ (B)			
C103	US064100	CERAMIC CAPACITOR-B (CHIP)	0.0100 50V K RECT.	チップセラ (B)			
C105	US064100	CERAMIC CAPACITOR-B (CHIP)	0.0100 50V K RECT.	チップセラ (B)			
C107	US14510R	CERAMIC CAPACITOR-F (CHIP)	0.1000 25V Z RECT.	チップセラ (F)			01
C108	US064100	CERAMIC CAPACITOR-B (CHIP)	0.0100 50V K RECT.	チップセラ (B)			
C109	WG888300	MULTILAYER CERAMIC CAP.	10.0 6.3V K TP	チップ積層セラコン			
C110	WG888300	MULTILAYER CERAMIC CAP.	10.0 6.3V K TP	チップ積層セラコン			
C111	US064100	CERAMIC CAPACITOR-B (CHIP)	0.0100 50V K RECT.	チップセラ (B)			
-113	US064100	CERAMIC CAPACITOR-B (CHIP)	0.0100 50V K RECT.	チップセラ (B)			
C114	US14510R	CERAMIC CAPACITOR-F (CHIP)	0.1000 25V Z RECT.	チップセラ (F)			01
C115	UF03747R	ELECTROLYTIC CAPACITOR	47 16V	チップケミコン			
C116	US064100	CERAMIC CAPACITOR-B (CHIP)	0.0100 50V K RECT.	チップセラ (B)			
-119	US064100	CERAMIC CAPACITOR-B (CHIP)	0.0100 50V K RECT.	チップセラ (B)			
C120	US063270	CERAMIC CAPACITOR-B (CHIP)	2700P 50V K RECT.	チップセラ (B)			
C121	US063270	CERAMIC CAPACITOR-B (CHIP)	2700P 50V K RECT.	チップセラ (B)			
C122	US14510R	CERAMIC CAPACITOR-F (CHIP)	0.1000 25V Z RECT.	チップセラ (F)			01
C123	US063270	CERAMIC CAPACITOR-B (CHIP)	2700P 50V K RECT.	チップセラ (B)			
C124	US063270	CERAMIC CAPACITOR-B (CHIP)	2700P 50V K RECT.	チップセラ (B)			
C125	UF06610R	ELECTROLYTIC CAPACITOR	1 50V	チップケミコン			
C126	UF06610R	ELECTROLYTIC CAPACITOR	1 50V	チップケミコン			
C127	US062100	CERAMIC CAPACITOR-SL CHIP	100P 50V J RECT.	チップセラ (S L)			
-141	US062100	CERAMIC CAPACITOR-SL CHIP	100P 50V J RECT.	チップセラ (S L)			
C142	WG251600	CHIP CERAMIC CAPACITOR	4.7 6.3V K RECT.	チップセラ			01
C143	US062100	CERAMIC CAPACITOR-SL CHIP	100P 50V J RECT.	チップセラ (S L)			
-146	US062100	CERAMIC CAPACITOR-SL CHIP	100P 50V J RECT.	チップセラ (S L)			
C147	US063100	CERAMIC CAPACITOR-B (CHIP)	1000P 50V K RECT.	チップセラ (B)			
C148	US062100	CERAMIC CAPACITOR-SL CHIP	100P 50V J RECT.	チップセラ (S L)			
-151	US062100	CERAMIC CAPACITOR-SL CHIP	100P 50V J RECT.	チップセラ (S L)			
C154	US062100	CERAMIC CAPACITOR-SL CHIP	100P 50V J RECT.	チップセラ (S L)			
C156	US062100	CERAMIC CAPACITOR-SL CHIP	100P 50V J RECT.	チップセラ (S L)			
C158	UF03810R	ELECTROLYTIC CAPACITOR	100 16V	チップケミコン			01
C160	WG888300	MULTILAYER CERAMIC CAP.	10.0 6.3V K TP	チップ積層セラコン			
C161	US14510R	CERAMIC CAPACITOR-F (CHIP)	0.1000 25V Z RECT.	チップセラ (F)			01
C163	US062100	CERAMIC CAPACITOR-SL CHIP	100P 50V J RECT.	チップセラ (S L)			
C164	US14510R	CERAMIC CAPACITOR-F (CHIP)	0.1000 25V Z RECT.	チップセラ (F)			01
C165	US063100	CERAMIC CAPACITOR-B (CHIP)	1000P 50V K RECT.	チップセラ (B)			
C166	US063100	CERAMIC CAPACITOR-B (CHIP)	1000P 50V K RECT.	チップセラ (B)			
C167	US06127R	CERAMIC CAPACITOR-CH CHIP	27P 50V J RECT.	チップセラ (C H)			01
C169	UF03810R	ELECTROLYTIC CAPACITOR	100 16V	チップケミコン			01
C170	US06127R	CERAMIC CAPACITOR-CH CHIP	27P 50V J RECT.	チップセラ (C H)			01
C171	UF157470	ELECTROLYTIC CAPACITOR	47 35V	チップケミコン			01
C173	US06127R	CERAMIC CAPACITOR-CH CHIP	27P 50V J RECT.	チップセラ (C H)			01
C174	US14510R	CERAMIC CAPACITOR-F (CHIP)	0.1000 25V Z RECT.	チップセラ (F)			01
C175	US06127R	CERAMIC CAPACITOR-CH CHIP	27P 50V J RECT.	チップセラ (C H)			01
C176	US14510R	CERAMIC CAPACITOR-F (CHIP)	0.1000 25V Z RECT.	チップセラ (F)			01
C177	US06127R	CERAMIC CAPACITOR-CH CHIP	27P 50V J RECT.	チップセラ (C H)			01
C178	US062390	CERAMIC CAPACITOR-SL CHIP	390P 50V J RECT.	チップセラ (S L)			
C179	US06127R	CERAMIC CAPACITOR-CH CHIP	27P 50V J RECT.	チップセラ (C H)			01
C194	UF03810R	ELECTROLYTIC CAPACITOR	100 16V	チップケミコン			01
C197	US063100	CERAMIC CAPACITOR-B (CHIP)	1000P 50V K RECT.	チップセラ (B)			
C202	US062100	CERAMIC CAPACITOR-SL CHIP	100P 50V J RECT.	チップセラ (S L)			
C203	US064100	CERAMIC CAPACITOR-B (CHIP)	0.0100 50V K RECT.	チップセラ (B)			
C210	US064100	CERAMIC CAPACITOR-B (CHIP)	0.0100 50V K RECT.	チップセラ (B)			

*: New Parts (新規部品)

RANK : Japan only

REF. NO.	PART NO.	DESCRIPTION	部 品 名	REMARKS	QTY	RANK
-223	US064100	CERAMIC CAPACITOR-B (CHIP)	0.0100 50V K RECT.	チップセラ (B)		
C225	US064100	CERAMIC CAPACITOR-B (CHIP)	0.0100 50V K RECT.	チップセラ (B)		
C230	US062470	CERAMIC CAPACITOR-SL CHIP	470P 50V J RECT.	チップセラ (S L)		
C231	US062470	CERAMIC CAPACITOR-SL CHIP	470P 50V J RECT.	チップセラ (S L)		
C234	WG888300	MULTILAYER CERAMIC CAP.	10.0 6.3V K TP	チップ積層セラコン		
C236	US062100	CERAMIC CAPACITOR-SL CHIP	100P 50V J RECT.	チップセラ (S L)		
C237	US062100	CERAMIC CAPACITOR-SL CHIP	100P 50V J RECT.	チップセラ (S L)		
C238	US14510R	CERAMIC CAPACITOR-F (CHIP)	0.1000 25V Z RECT.	チップセラ (F)		01
-240	US14510R	CERAMIC CAPACITOR-F (CHIP)	0.1000 25V Z RECT.	チップセラ (F)		01
C243	US064100	CERAMIC CAPACITOR-B (CHIP)	0.0100 50V K RECT.	チップセラ (B)		
-246	US064100	CERAMIC CAPACITOR-B (CHIP)	0.0100 50V K RECT.	チップセラ (B)		
C247	US063100	CERAMIC CAPACITOR-B (CHIP)	1000P 50V K RECT.	チップセラ (B)		
C248	US063100	CERAMIC CAPACITOR-B (CHIP)	1000P 50V K RECT.	チップセラ (B)		
C249	US062470	CERAMIC CAPACITOR-SL CHIP	470P 50V J RECT.	チップセラ (S L)		
C250	US064100	CERAMIC CAPACITOR-B (CHIP)	0.0100 50V K RECT.	チップセラ (B)		
-280	US064100	CERAMIC CAPACITOR-B (CHIP)	0.0100 50V K RECT.	チップセラ (B)		
C283	US14510R	CERAMIC CAPACITOR-F (CHIP)	0.1000 25V Z RECT.	チップセラ (F)		01
-291	US14510R	CERAMIC CAPACITOR-F (CHIP)	0.1000 25V Z RECT.	チップセラ (F)		01
C292	WD176500	CHIP CERAMIC CAPACITOR	1.0000 6.3V K RECT	チップセラ		01
C293	US064100	CERAMIC CAPACITOR-B (CHIP)	0.0100 50V K RECT.	チップセラ (B)		
C294	US064100	CERAMIC CAPACITOR-B (CHIP)	0.0100 50V K RECT.	チップセラ (B)		
CN501	WC195200	CONNECTOR, FFC/FPC	52808 14P TE	FFC / FPC コネクタ		01
CN601	WA62570R	FFC CONNECTOR	52793 14P SE	FFC コネクタ		
CN601	WF377500	FPC CONNECTOR	YSF5 14P SE	FPC コネクタ		
CN701	WA745600	FFC CONNECTOR	52793 7P SE	FFC コネクタ		
CN701	WG950800	FPC CONNECTOR	YSF5 7P SE	FPC コネクタ		
CN702	VK024700	CONNECTOR BASE PIN	52147 3P TE	ワイヤートラップ		01
CN801	VK02560R	CONNECTOR BASE PIN	52147 12P TE	ワイヤートラップ		
CN802	VK025100	CONNECTOR BASE PIN	52147 7P TE	ワイヤートラップ		
CN803	VK024900	CONNECTOR BASE PIN	52147 5P TE	ワイヤートラップ		
CN901	WC336500	FFC CONNECTOR	52793 27P SE	FFC コネクタ		
CN901	WF377900	FPC CONNECTOR	YSF5 27P SE	FPC コネクタ		
D11	VT332900	DIODE	1SS355 TE-17 TP	ダイオード		
D11	WG139300	DIODE	KDS4148U-RTK/P TE-	ダイオード		
-18	VT332900	DIODE	1SS355 TE-17 TP	ダイオード		
-18	WG139300	DIODE	KDS4148U-RTK/P TE-	ダイオード		
D27	V2376600	DIODE	RB500V-40 TAPING	ショットキダイオード		
DA1	V9424900	DIODE ARRAY	1SS372 TE85L	ダイオードアレイ		01
DA1	WH107100	DIODE ARRAY	MA3Z79300L 0.10 X2	ダイオードアレイ		
-4	V9424900	DIODE ARRAY	1SS372 TE85L	ダイオードアレイ		01
-4	WH107100	DIODE ARRAY	MA3Z79300L 0.10 X2	ダイオードアレイ		
IC1	X5889A0R	IC	BA33BC0FP 3.3V	I	C	REGULATOR +3.3V
IC4	X5422A00	IC	S1D13700F01A100 LC	I	C	LCD CONTROLLER
IC5	X4374A0R	IC	S-80136ANMC-JCVT2G	I	C	RESET
IC5	X5888A0R	IC	BD45365G	I	C	
IC6	X9292A00	IC	R1172H121D-T1-F	I	C	REGULATOR +1.2V
IC7	X8810A00	IC	R8A02032BG	I	C	SWX02
IC8	X3584C00	IC	W9812G6GH-6	I	C	
IC8	X3585E00	IC	K4S281632K-UC75000	I	C	SDRAM 128M
IC8	X6970B00	IC	M12L128168A-7TG	I	C	
* IC9	X9859100	IC	MR27V12852L-10MTA0	I	C	P2ROM 128M(PROGRAM)
IC10	X3042D00	IC	MX29LV160CBTC-70G	I	C	FLASH ROM 16M
IC10	X8950A00	IC	EN29LV160AB-70TCP	I	C	
* IC11	X9860100	IC	MR26V25602L-108TA0	I	C	P2ROM 256M(WAVE)
IC13	X4463A00	IC	SN74LV08APWR	I	C	AND
IC14	X6040A01	IC	AK4385ET	I	C	D/A CONVERTER
IC16	X2331A0R	IC	NJM4580E(TE2)	I	C	OPAMP
IC17	XZ56010R	IC	UPD789022GB-A15-8E	I	C	CPU
IC18	X7569A00	IC	R5520H001B-T1-F US	I	C	USB HIGH SIDE SWITCH
IC19	X7371A00	IC	MC34063EBD-TR	I	C	DC-DC CONVERTER
IC20	X6688A0R	IC	SN74LV14APWR	I	C	INVERTER
IC24	X3824A00	IC	SN74AHCT08PWR	I	C	AND
L1	VY65720R	CHIP INDUCTANCE	600 BK1608HM601-T	チップインダクタ		01
L2	VY65720R	CHIP INDUCTANCE	600 BK1608HM601-T	チップインダクタ		01
L1	WG595200	CHIP INDUCTANCE	GZ1608D601 1608	チップインダクタ		
L2	WG595200	CHIP INDUCTANCE	GZ1608D601 1608	チップインダクタ		
L6	VY65720R	CHIP INDUCTANCE	600 BK1608HM601-T	チップインダクタ		01
L6	WG595200	CHIP INDUCTANCE	GZ1608D601 1608	チップインダクタ		
L7	WG834800	COIL FIXED	DLW21HN900SQ2L	コイル		
L8	WG834800	COIL FIXED	DLW21HN900SQ2L	コイル		

* : New Parts (新規部品)

RANK : Japan only

DM

REF NO.	PART NO.	DESCRIPTION		部 品 名	REMARKS	QTY	RANK
L9	VY65720R	CHIP INDUCTANCE	600 BK1608HM601-T	チ ッ プ イ ン ダ ク タ			01
L9	WG595200	CHIP INDUCTANCE	GZ1608D601 1608	チ ッ プ イ ン ダ ク タ			
L10	V858970R	CHOKE COIL	330U SLF7045T-331M	チ ッ プ イ ン ダ ク タ			02
L12	VY65720R	CHIP INDUCTANCE	600 BK1608HM601-T	チ ッ プ イ ン ダ ク タ			01
L12	WG595200	CHIP INDUCTANCE	GZ1608D601 1608	チ ッ プ イ ン ダ ク タ			
L13	V270320R	CHIP INDUCTANCE	BLM18BB221SN1D	チ ッ プ イ ン ダ ク タ			01
-15	V270320R	CHIP INDUCTANCE	BLM18BB221SN1D	チ ッ プ イ ン ダ ク タ			01
L37	V270320R	CHIP INDUCTANCE	BLM18BB221SN1D	チ ッ プ イ ン ダ ク タ			01
L38	V270320R	CHIP INDUCTANCE	BLM18BB221SN1D	チ ッ プ イ ン ダ ク タ			01
R16	RD35747R	CARBON RESISTOR 1/16 CHIP	47.0K 63M J RECT.	チ ッ プ 抵 抗			01
R17	RD356470	CARBON RESISTOR 1/16 CHIP	4.7K 63M J RECT.	チ ッ プ 抵 抗			
R22	RD357100	CARBON RESISTOR 1/16 CHIP	10.0K 63M J RECT.	チ ッ プ 抵 抗			01
R23	RD356100	CARBON RESISTOR 1/16 CHIP	1.0K 63M J RECT.	チ ッ プ 抵 抗			01
R25	RD357100	CARBON RESISTOR 1/16 CHIP	10.0K 63M J RECT.	チ ッ プ 抵 抗			01
-27	RD357100	CARBON RESISTOR 1/16 CHIP	10.0K 63M J RECT.	チ ッ プ 抵 抗			01
R28	RD350001	CARBON RESISTOR 1/16 CHIP	0 63M J RECT.	チ ッ プ 抵 抗			
R30	RD357100	CARBON RESISTOR 1/16 CHIP	10.0K 63M J RECT.	チ ッ プ 抵 抗			01
R31	RD350001	CARBON RESISTOR 1/16 CHIP	0 63M J RECT.	チ ッ プ 抵 抗			
R34	RD359100	CARBON RESISTOR 1/16 CHIP	1.0M 63M J RECT.	チ ッ プ 抵 抗			
R35	RD354470	CARBON RESISTOR 1/16 CHIP	47.0 63M J RECT.	チ ッ プ 抵 抗			
-42	RD354470	CARBON RESISTOR 1/16 CHIP	47.0 63M J RECT.	チ ッ プ 抵 抗			
R44	RD354470	CARBON RESISTOR 1/16 CHIP	47.0 63M J RECT.	チ ッ プ 抵 抗			
R45	RD354470	CARBON RESISTOR 1/16 CHIP	47.0 63M J RECT.	チ ッ プ 抵 抗			
R46	RD35527R	CARBON RESISTOR 1/16 CHIP	270.0 63M J RECT.	チ ッ プ 抵 抗			01
R47	RD356100	CARBON RESISTOR 1/16 CHIP	1.0K 63M J RECT.	チ ッ プ 抵 抗			01
R48	RD354470	CARBON RESISTOR 1/16 CHIP	47.0 63M J RECT.	チ ッ プ 抵 抗			
-50	RD354470	CARBON RESISTOR 1/16 CHIP	47.0 63M J RECT.	チ ッ プ 抵 抗			
R51	RD357100	CARBON RESISTOR 1/16 CHIP	10.0K 63M J RECT.	チ ッ プ 抵 抗			01
R52	RD354680	CARBON RESISTOR 1/16 CHIP	68.0 63M J RECT.	チ ッ プ 抵 抗			
R53	RD354680	CARBON RESISTOR 1/16 CHIP	68.0 63M J RECT.	チ ッ プ 抵 抗			
R54	RD350001	CARBON RESISTOR 1/16 CHIP	0 63M J RECT.	チ ッ プ 抵 抗			
R55	RD350001	CARBON RESISTOR 1/16 CHIP	0 63M J RECT.	チ ッ プ 抵 抗			
R56	RD354470	CARBON RESISTOR 1/16 CHIP	47.0 63M J RECT.	チ ッ プ 抵 抗			
R57	RD356100	CARBON RESISTOR 1/16 CHIP	1.0K 63M J RECT.	チ ッ プ 抵 抗			01
R58	RD357100	CARBON RESISTOR 1/16 CHIP	10.0K 63M J RECT.	チ ッ プ 抵 抗			01
R60	RD350001	CARBON RESISTOR 1/16 CHIP	0 63M J RECT.	チ ッ プ 抵 抗			
R61	RD355100	CARBON RESISTOR 1/16 CHIP	100.0 63M J RECT.	チ ッ プ 抵 抗			
R62	RD355100	CARBON RESISTOR 1/16 CHIP	100.0 63M J RECT.	チ ッ プ 抵 抗			
R64	RD354470	CARBON RESISTOR 1/16 CHIP	47.0 63M J RECT.	チ ッ プ 抵 抗			
R65	RD354470	CARBON RESISTOR 1/16 CHIP	47.0 63M J RECT.	チ ッ プ 抵 抗			
R66	RD355100	CARBON RESISTOR 1/16 CHIP	100.0 63M J RECT.	チ ッ プ 抵 抗			
R68	RD355100	CARBON RESISTOR 1/16 CHIP	100.0 63M J RECT.	チ ッ プ 抵 抗			
-71	RD355100	CARBON RESISTOR 1/16 CHIP	100.0 63M J RECT.	チ ッ プ 抵 抗			
R73	RD357100	CARBON RESISTOR 1/16 CHIP	10.0K 63M J RECT.	チ ッ プ 抵 抗			01
R74	RD355150	CARBON RESISTOR 1/16 CHIP	150.0 63M J RECT.	チ ッ プ 抵 抗			
R75	RD355220	CARBON RESISTOR 1/16 CHIP	220.0 63M J RECT.	チ ッ プ 抵 抗			
R78	RD357100	CARBON RESISTOR 1/16 CHIP	10.0K 63M J RECT.	チ ッ プ 抵 抗			01
R80	RD354470	CARBON RESISTOR 1/16 CHIP	47.0 63M J RECT.	チ ッ プ 抵 抗			
R81	RD356220	CARBON RESISTOR 1/16 CHIP	2.2K 63M J RECT.	チ ッ プ 抵 抗			01
R82	RD356220	CARBON RESISTOR 1/16 CHIP	2.2K 63M J RECT.	チ ッ プ 抵 抗			01
R83	RD354470	CARBON RESISTOR 1/16 CHIP	47.0 63M J RECT.	チ ッ プ 抵 抗			
R84	RD354470	CARBON RESISTOR 1/16 CHIP	47.0 63M J RECT.	チ ッ プ 抵 抗			
R85	RD357100	CARBON RESISTOR 1/16 CHIP	10.0K 63M J RECT.	チ ッ プ 抵 抗			01
R86	RD357100	CARBON RESISTOR 1/16 CHIP	10.0K 63M J RECT.	チ ッ プ 抵 抗			01
R87	RD357220	CARBON RESISTOR 1/16 CHIP	22.0K 63M J RECT.	チ ッ プ 抵 抗			01
R89	RD357220	CARBON RESISTOR 1/16 CHIP	22.0K 63M J RECT.	チ ッ プ 抵 抗			01
R90	RD357220	CARBON RESISTOR 1/16 CHIP	22.0K 63M J RECT.	チ ッ プ 抵 抗			01
R94	RD355100	CARBON RESISTOR 1/16 CHIP	100.0 63M J RECT.	チ ッ プ 抵 抗			
R95	RD355100	CARBON RESISTOR 1/16 CHIP	100.0 63M J RECT.	チ ッ プ 抵 抗			
R96	RD356100	CARBON RESISTOR 1/16 CHIP	1.0K 63M J RECT.	チ ッ プ 抵 抗			01
-98	RD356100	CARBON RESISTOR 1/16 CHIP	1.0K 63M J RECT.	チ ッ プ 抵 抗			01
R99	RD356120	CARBON RESISTOR 1/16 CHIP	1.2K 63M J RECT.	チ ッ プ 抵 抗			
R100	RD356150	CARBON RESISTOR 1/16 CHIP	1.5K 63M J RECT.	チ ッ プ 抵 抗			
R101	RD354470	CARBON RESISTOR 1/16 CHIP	47.0 63M J RECT.	チ ッ プ 抵 抗			
R102	RD357220	CARBON RESISTOR 1/16 CHIP	22.0K 63M J RECT.	チ ッ プ 抵 抗			01
-104	RD357220	CARBON RESISTOR 1/16 CHIP	22.0K 63M J RECT.	チ ッ プ 抵 抗			01
R105	RD356100	CARBON RESISTOR 1/16 CHIP	1.0K 63M J RECT.	チ ッ プ 抵 抗			01
R106	RD356100	CARBON RESISTOR 1/16 CHIP	1.0K 63M J RECT.	チ ッ プ 抵 抗			01
R108	RD356100	CARBON RESISTOR 1/16 CHIP	1.0K 63M J RECT.	チ ッ プ 抵 抗			01
R109	RD355100	CARBON RESISTOR 1/16 CHIP	100.0 63M J RECT.	チ ッ プ 抵 抗			

*: New Parts (新規部品)

RANK : Japan only

REF NO.	PART NO.	DESCRIPTION	部 品 名	REMARKS	QTY	RANK
R110	RD356560	CARBON RESISTOR 1/16 CHIP	チ ッ ブ 抵 抗	5.6K 63M J RECT.		
-113	RD356560	CARBON RESISTOR 1/16 CHIP	チ ッ ブ 抵 抗	5.6K 63M J RECT.		
R114	RD356100	CARBON RESISTOR 1/16 CHIP	チ ッ ブ 抵 抗	1.0K 63M J RECT.		01
-116	RD356100	CARBON RESISTOR 1/16 CHIP	チ ッ ブ 抵 抗	1.0K 63M J RECT.		01
R117	RD356220	CARBON RESISTOR 1/16 CHIP	チ ッ ブ 抵 抗	2.2K 63M J RECT.		01
-120	RD356220	CARBON RESISTOR 1/16 CHIP	チ ッ ブ 抵 抗	2.2K 63M J RECT.		01
R121	RD356100	CARBON RESISTOR 1/16 CHIP	チ ッ ブ 抵 抗	1.0K 63M J RECT.		01
R122	RD356100	CARBON RESISTOR 1/16 CHIP	チ ッ ブ 抵 抗	1.0K 63M J RECT.		01
R123	RD35518R	CARBON RESISTOR 1/16 CHIP	チ ッ ブ 抵 抗	180.0 63M J RECT.		01
-126	RD35518R	CARBON RESISTOR 1/16 CHIP	チ ッ ブ 抵 抗	180.0 63M J RECT.		01
R127	RD357220	CARBON RESISTOR 1/16 CHIP	チ ッ ブ 抵 抗	22.0K 63M J RECT.		01
-132	RD357220	CARBON RESISTOR 1/16 CHIP	チ ッ ブ 抵 抗	22.0K 63M J RECT.		01
R133	RD355100	CARBON RESISTOR 1/16 CHIP	チ ッ ブ 抵 抗	100.0 63M J RECT.		
-142	RD355100	CARBON RESISTOR 1/16 CHIP	チ ッ ブ 抵 抗	100.0 63M J RECT.		
R143	RD356100	CARBON RESISTOR 1/16 CHIP	チ ッ ブ 抵 抗	1.0K 63M J RECT.		01
R144	RD355100	CARBON RESISTOR 1/16 CHIP	チ ッ ブ 抵 抗	100.0 63M J RECT.		
R145	RD355100	CARBON RESISTOR 1/16 CHIP	チ ッ ブ 抵 抗	100.0 63M J RECT.		
R146	RD356100	CARBON RESISTOR 1/16 CHIP	チ ッ ブ 抵 抗	1.0K 63M J RECT.		01
R148	RD357100	CARBON RESISTOR 1/16 CHIP	チ ッ ブ 抵 抗	10.0K 63M J RECT.		01
R149	RD357100	CARBON RESISTOR 1/16 CHIP	チ ッ ブ 抵 抗	10.0K 63M J RECT.		01
R150	RD35747R	CARBON RESISTOR 1/16 CHIP	チ ッ ブ 抵 抗	47.0K 63M J RECT.		01
R151	RD357220	CARBON RESISTOR 1/16 CHIP	チ ッ ブ 抵 抗	22.0K 63M J RECT.		01
R152	RD35422R	CARBON RESISTOR 1/16 CHIP	チ ッ ブ 抵 抗	22.0 63M J RECT.		01
R153	RD35422R	CARBON RESISTOR 1/16 CHIP	チ ッ ブ 抵 抗	22.0 63M J RECT.		01
R154	RD357100	CARBON RESISTOR 1/16 CHIP	チ ッ ブ 抵 抗	10.0K 63M J RECT.		01
R155	RD357150	CARBON RESISTOR 1/16 CHIP	チ ッ ブ 抵 抗	15.0K 63M J RECT.		
R156	RD356100	CARBON RESISTOR 1/16 CHIP	チ ッ ブ 抵 抗	1.0K 63M J RECT.		01
R157	RD357150	CARBON RESISTOR 1/16 CHIP	チ ッ ブ 抵 抗	15.0K 63M J RECT.		
R158	RD35627R	CARBON RESISTOR 1/16 CHIP	チ ッ ブ 抵 抗	2.7K 63M J RECT.		01
R159	RD356120	CARBON RESISTOR 1/16 CHIP	チ ッ ブ 抵 抗	1.2K 63M J RECT.		
R160	RD35422R	CARBON RESISTOR 1/16 CHIP	チ ッ ブ 抵 抗	22.0 63M J RECT.		01
R161	RD35422R	CARBON RESISTOR 1/16 CHIP	チ ッ ブ 抵 抗	22.0 63M J RECT.		01
R162	RD356220	CARBON RESISTOR 1/16 CHIP	チ ッ ブ 抵 抗	2.2K 63M J RECT.		01
R164	RD357100	CARBON RESISTOR 1/16 CHIP	チ ッ ブ 抵 抗	10.0K 63M J RECT.		01
R165	RD356100	CARBON RESISTOR 1/16 CHIP	チ ッ ブ 抵 抗	1.0K 63M J RECT.		01
R166	RD35747R	CARBON RESISTOR 1/16 CHIP	チ ッ ブ 抵 抗	47.0K 63M J RECT.		01
R167	RD35747R	CARBON RESISTOR 1/16 CHIP	チ ッ ブ 抵 抗	47.0K 63M J RECT.		01
R169	RD356150	CARBON RESISTOR 1/16 CHIP	チ ッ ブ 抵 抗	1.5K 63M J RECT.		
R174	RD350001	CARBON RESISTOR 1/16 CHIP	チ ッ ブ 抵 抗	0 63M J RECT.		
R177	RF457220	CHIP RESISTOR 1/16W	チ ッ ブ 抵 抗	22.0K D RECT.		
R178	RD355220	CARBON RESISTOR 1/16 CHIP	チ ッ ブ 抵 抗	220.0 63M J RECT.		
R179	RF456100	CHIP RESISTOR 1/16W	チ ッ ブ 抵 抗	1.0K D RECT.		
R181	RD15310R	CARBON RESISTOR 1/4,CHIP	チ ッ ブ 抵 抗	1.0 1/4 J TP		01
R182	RD15310R	CARBON RESISTOR 1/4,CHIP	チ ッ ブ 抵 抗	1.0 1/4 J TP		01
R185	RD357100	CARBON RESISTOR 1/16 CHIP	チ ッ ブ 抵 抗	10.0K 63M J RECT.		01
R186	RD356100	CARBON RESISTOR 1/16 CHIP	チ ッ ブ 抵 抗	1.0K 63M J RECT.		01
R187	RD357100	CARBON RESISTOR 1/16 CHIP	チ ッ ブ 抵 抗	10.0K 63M J RECT.		01
R189	RD35422R	CARBON RESISTOR 1/16 CHIP	チ ッ ブ 抵 抗	22.0 63M J RECT.		01
-191	RD35422R	CARBON RESISTOR 1/16 CHIP	チ ッ ブ 抵 抗	22.0 63M J RECT.		01
R192	RD354680	CARBON RESISTOR 1/16 CHIP	チ ッ ブ 抵 抗	68.0 63M J RECT.		
R193	RD354680	CARBON RESISTOR 1/16 CHIP	チ ッ ブ 抵 抗	68.0 63M J RECT.		
R194	RD356220	CARBON RESISTOR 1/16 CHIP	チ ッ ブ 抵 抗	2.2K 63M J RECT.		01
R195	RD356220	CARBON RESISTOR 1/16 CHIP	チ ッ ブ 抵 抗	2.2K 63M J RECT.		01
R196	RD357100	CARBON RESISTOR 1/16 CHIP	チ ッ ブ 抵 抗	10.0K 63M J RECT.		01
-198	RD357100	CARBON RESISTOR 1/16 CHIP	チ ッ ブ 抵 抗	10.0K 63M J RECT.		01
R201	RD354470	CARBON RESISTOR 1/16 CHIP	チ ッ ブ 抵 抗	47.0 63M J RECT.		
R202	RD357100	CARBON RESISTOR 1/16 CHIP	チ ッ ブ 抵 抗	10.0K 63M J RECT.		01
R203	RD354470	CARBON RESISTOR 1/16 CHIP	チ ッ ブ 抵 抗	47.0 63M J RECT.		
R207	RD15310R	CARBON RESISTOR 1/4 CHIP	チ ッ ブ 抵 抗	1.0 1/4 J TP		01
R210	RD355100	CARBON RESISTOR 1/16 CHIP	チ ッ ブ 抵 抗	100.0 63M J RECT.		
R211	RD355100	CARBON RESISTOR 1/16 CHIP	チ ッ ブ 抵 抗	100.0 63M J RECT.		
R212	RD356100	CARBON RESISTOR 1/16 CHIP	チ ッ ブ 抵 抗	1.0K 63M J RECT.		01
R213	RD356100	CARBON RESISTOR 1/16 CHIP	チ ッ ブ 抵 抗	1.0K 63M J RECT.		01
R214	RD35747R	CARBON RESISTOR 1/16 CHIP	チ ッ ブ 抵 抗	47.0K 63M J RECT.		01
R215	RD35747R	CARBON RESISTOR 1/16 CHIP	チ ッ ブ 抵 抗	47.0K 63M J RECT.		01
R216	RD355100	CARBON RESISTOR 1/16 CHIP	チ ッ ブ 抵 抗	100.0 63M J RECT.		
R219	RD354680	CARBON RESISTOR 1/16 CHIP	チ ッ ブ 抵 抗	68.0 63M J RECT.		
-226	RD354680	CARBON RESISTOR 1/16 CHIP	チ ッ ブ 抵 抗	68.0 63M J RECT.		
R227	RD354470	CARBON RESISTOR 1/16 CHIP	チ ッ ブ 抵 抗	47.0 63M J RECT.		
-234	RD354470	CARBON RESISTOR 1/16 CHIP	チ ッ ブ 抵 抗	47.0 63M J RECT.		

DM,PNL

REF NO.	PART NO.	DESCRIPTION		部 品 名	REMARKS	QTY	RANK
R235	RD35422R	CARBON RESISTOR 1/16 CHIP	22.0 63M J RECT.	チ ッ プ 抵 抗			01
R236	RD35422R	CARBON RESISTOR 1/16 CHIP	22.0 63M J RECT.	チ ッ プ 抵 抗			01
R239	RD35422R	CARBON RESISTOR 1/16 CHIP	22.0 63M J RECT.	チ ッ プ 抵 抗			01
R240	RD355100	CARBON RESISTOR 1/16 CHIP	100.0 63M J RECT.	チ ッ プ 抵 抗			01
R241	RD355100	CARBON RESISTOR 1/16 CHIP	100.0 63M J RECT.	チ ッ プ 抵 抗			01
RA3	WH211800	RESISTOR ARRAY	10K X 4	抵 抗 ア レ イ			
-6	WH211800	RESISTOR ARRAY	10K X 4	抵 抗 ア レ イ			
RA7	WH206600	RESISTOR ARRAY	68 X 4	抵 抗 ア レ イ			01
-16	WH206600	RESISTOR ARRAY	68 X 4	抵 抗 ア レ イ			01
RA17	WH211800	RESISTOR ARRAY	10K X 4	抵 抗 ア レ イ			
RA22	WH206200	RESISTOR ARRAY	47 X 4	抵 抗 ア レ イ			01
-27	WH206200	RESISTOR ARRAY	47 X 4	抵 抗 ア レ イ			01
RA29	WH205400	RESISTOR ARRAY	22 X 4	抵 抗 ア レ イ			01
-31	WH205400	RESISTOR ARRAY	22 X 4	抵 抗 ア レ イ			01
RA32	WH206600	RESISTOR ARRAY	68 X 4	抵 抗 ア レ イ			01
-41	WH206600	RESISTOR ARRAY	68 X 4	抵 抗 ア レ イ			01
TR3	VV556500	TRANSISTOR	2SA1037AK-T146 Q,R,S	ト ラ ン ジ ス タ 2 S A			
TR3	WC52950R	TRANSISTOR	KTA1504S-Y,GR-RTK	ト ラ ン ジ ス タ			
TR6	VV556400	TRANSISTOR	2SC2412K Q,R,S	ト ラ ン ジ ス タ 2 S C			
TR7	VV556400	TRANSISTOR	2SC2412K Q,R,S	ト ラ ン ジ ス タ 2 S C			
TR6	WC52940R	TRANSISTOR	2SCKTC3875S-Y,GR-RTK	ト ラ ン ジ ス タ			01
TR7	WC52940R	TRANSISTOR	2SCKTC3875S-Y,GR-RTK	ト ラ ン ジ ス タ			01
TR8	VV556500	TRANSISTOR	2SA1037AK-T146 Q,R,S	ト ラ ン ジ ス タ 2 S A			
TR8	WC52950R	TRANSISTOR	KTA1504S-Y,GR-RTK/	ト ラ ン ジ ス タ			
X1	WE19440R	QUARTZ CRYSTAL UNIT	16.9344M HC-49S-SM	水 晶 振 動 子			01
X2	WH521200	QUARTZ CRYSTAL UNIT	SG-310SCF 48MHZ	水 晶 振 動 器			04
X3	WA78210R	CERAMIC RESONATOR	5.000M	セ ラ ミ ッ ク 振 動 子			
	WH334000	CIRCUIT BOARD	PNL	P N L シ ー ト	(X7723D0)		16
C101	US14510R	CERAMIC CAPACITOR-F (CHIP)	0.1000 25V Z RECT.	チ ッ プ セ ラ (F)			01
-104	US14510R	CERAMIC CAPACITOR-F (CHIP)	0.1000 25V Z RECT.	チ ッ プ セ ラ (F)			01
C105	UF02810R	ELECTROLYTIC CAPACITOR	100 10V	チ ッ プ ケ ミ コ ン			01
C106	US14510R	CERAMIC CAPACITOR-F (CHIP)	0.1000 25V Z RECT.	チ ッ プ セ ラ (F)			01
C107	US062100	CERAMIC CAPACITOR-SL CHIP	100P 50V J RECT.	チ ッ プ セ ラ (S L)			
-133	US062100	CERAMIC CAPACITOR-SL CHIP	100P 50V J RECT.	チ ッ プ セ ラ (S L)			
CN101	V9335000	CONNECTOR, FFC/FPC	52808 21P TE	F F C / F P C コ ネ ク タ			01
CN102	WC195200	CONNECTOR, FFC/FPC	52808 14P TE	F F C / F P C コ ネ ク タ			01
CN103	WC194600	CONNECTOR, FFC/FPC	52808 7P TE	F F C / F P C コ ネ ク タ			
D101	VR49650R	DIODE	MA2J1110GL TP	チ ッ プ ダイ オード			01
D101	VT332900	DIODE	1SS355 TE-17 TP	ダ イ オード			
-108	VR49650R	DIODE	MA2J1110GL TP	チ ッ プ ダイ オード			01
-108	VT332900	DIODE	1SS355 TE-17 TP	ダ イ オード			
IC101	XS71120R	IC	MN101C027YB 1CHITS	I C	CPU		06
LD101	WF300900	LED (CHIP)	SML-512DW ORANGE	チ ッ プ L E D テー	ACMP		01
LD102	WF300900	LED (CHIP)	SML-512DW ORANGE	チ ッ プ L E D テー	INTRO I		01
LD103	WF300900	LED (CHIP)	SML-512DW ORANGE	チ ッ プ L E D テー	INTRO II		01
LD104	WF300900	LED (CHIP)	SML-512DW ORANGE	チ ッ プ L E D テー	INTRO III		01
LD105	WF300900	LED (CHIP)	SML-512DW ORANGE	チ ッ プ L E D テー	MAIN VARIATION A		01
LD106	WF300900	LED (CHIP)	SML-512DW ORANGE	チ ッ プ L E D テー	MAIN VARIATION B		01
LD107	WF300900	LED (CHIP)	SML-512DW ORANGE	チ ッ プ L E D テー	MAIN VARIATION C		01
LD108	WF300900	LED (CHIP)	SML-512DW ORANGE	チ ッ プ L E D テー	MAIN VARIATION D		01
LD109	WF300900	LED (CHIP)	SML-512DW ORANGE	チ ッ プ L E D テー	ENDING/rit.I		01
LD110	WF300900	LED (CHIP)	SML-512DW ORANGE	チ ッ プ L E D テー	ENDING/rit.II		01
LD111	WF300900	LED (CHIP)	SML-512DW ORANGE	チ ッ プ L E D テー	ENDING/rit.III		01
LD112	WF300900	LED (CHIP)	SML-512DW ORANGE	チ ッ プ L E D テー	SYNC STOP		01
LD113	WF300900	LED (CHIP)	SML-512DW ORANGE	チ ッ プ L E D テー	SYNC START		01
LD114	WF300900	LED (CHIP)	SML-512DW ORANGE	チ ッ プ L E D テー	OTS LINK		01
LD115	WF300900	LED (CHIP)	SML-512DW ORANGE	チ ッ プ L E D テー	SONG MODE		01
LD116	WF300900	LED (CHIP)	SML-512DW ORANGE	チ ッ プ L E D テー	AUTO FILL IN		01
LD117	WF300900	LED (CHIP)	SML-512DW ORANGE	チ ッ プ L E D テー	REC		01
LD118	WF300900	LED (CHIP)	SML-512DW ORANGE	チ ッ プ L E D テー	START/STOP		01
LD119	WF30100R	LED (CHIP)	SML-012PTT86A GREEN	チ ッ プ L E D テー	START/STOP		01
R101	RD357100	CARBON RESISTOR 1/16 CHIP	10.0K 63M J RECT.	チ ッ プ 抵 抗			01
-106	RD357100	CARBON RESISTOR 1/16 CHIP	10.0K 63M J RECT.	チ ッ プ 抵 抗			01
R108	RD357100	CARBON RESISTOR 1/16 CHIP	10.0K 63M J RECT.	チ ッ プ 抵 抗			01
-113	RD357100	CARBON RESISTOR 1/16 CHIP	10.0K 63M J RECT.	チ ッ プ 抵 抗			01
R114	RD35530R	CARBON RESISTOR 1/16 CHIP	300.0 63M J RECT.	チ ッ プ 抵 抗			01
-131	RD35530R	CARBON RESISTOR 1/16 CHIP	300.0 63M J RECT.	チ ッ プ 抵 抗			01
R132	RD35520R	CARBON RESISTOR 1/16 CHIP	200.0 63M J RECT.	チ ッ プ 抵 抗			01
-149	RD35520R	CARBON RESISTOR 1/16 CHIP	200.0 63M J RECT.	チ ッ プ 抵 抗			01

* : New Parts (新規部品)

RANK : Japan only

PNL,PNC,PNR,61L,61H

REF NO.	PART NO.	DESCRIPTION		部 品 名	REMARKS	QTY	RANK
R150	RD35747R	CARBON RESISTOR 1/16 CHIP	47.0K 63M J RECT.	チ ッ プ 抵 抗			01
-157	RD35747R	CARBON RESISTOR 1/16 CHIP	47.0K 63M J RECT.	チ ッ プ 抵 抗			01
R158	RD355100	CARBON RESISTOR 1/16 CHIP	100.0 63M J RECT.	チ ッ プ 抵 抗			
-160	RD355100	CARBON RESISTOR 1/16 CHIP	100.0 63M J RECT.	チ ッ プ 抵 抗			
TA101	V856660R	TRANSISTOR ARRAY	TD62785FG-(5,EL)	ト ラ ン ジ ス タ ア レ イ			05
TR101	VY67760R	DIGITAL TRANSISTOR	DTC123JKA TP	デ ジ タ ル ト ラ ン ジ ス タ			01
-115	VY67760R	DIGITAL TRANSISTOR	DTC123JKA TP	デ ジ タ ル ト ラ ン ジ ス タ			01
X101	VY68120R	CERAMIC RESONATOR	CSTCC 8.0M	セ ラ ミ ッ ク 発 振 子			01
	WH333800	CIRCUIT BOARD	PNC	P N C シ ー ト	(WH50940)(X7978B0)		16
	WH333900	CIRCUIT BOARD	PNR	P N R シ ー ト	(WH50940)(X7978B0)		16
CN202	WJ097700	FFC CONNECTOR	52807 21P SE	F F C コ ネ ク タ			
CN301	VV678400	FFC CONNECTOR	52806 14P TE	F F C コ ネ ク タ			01
D201	VR49650R	DIODE	MA2J1110GL TP	チ ッ プ ダイ オード			01
D201	VT332900	DIODE	1SS355 TE-17 TP	ダイ オード			01
-208	VR49650R	DIODE	MA2J1110GL TP	チ ッ プ ダイ オード			01
-208	VT332900	DIODE	1SS355 TE-17 TP	ダイ オード			01
D301	VR49650R	DIODE	MA2J1110GL TP	チ ッ プ ダイ オード			01
D301	VT332900	DIODE	1SS355 TE-17 TP	ダイ オード			01
-308	VR49650R	DIODE	MA2J1110GL TP	チ ッ プ ダイ オード			01
-308	VT332900	DIODE	1SS355 TE-17 TP	ダイ オード			01
LD201	WF300900	LED (CHIP)	SML-512DW ORANGE	チ ッ プ L E D テー	REGISTRATION MEMORY 1		01
LD202	WF30100R	LED (CHIP)	SML-012PTT86A GREEN	チ ッ プ L E D テー	REGISTRATION MEMORY 1		01
LD203	WF300900	LED (CHIP)	SML-512DW ORANGE	チ ッ プ L E D テー	REGISTRATION MEMORY 2		01
LD204	WF30100R	LED (CHIP)	SML-012PTT86A GREEN	チ ッ プ L E D テー	REGISTRATION MEMORY 2		01
LD205	WF300900	LED (CHIP)	SML-512DW ORANGE	チ ッ プ L E D テー	REGISTRATION MEMORY 3		01
LD206	WF30100R	LED (CHIP)	SML-012PTT86A GREEN	チ ッ プ L E D テー	REGISTRATION MEMORY 3		01
LD207	WF300900	LED (CHIP)	SML-512DW ORANGE	チ ッ プ L E D テー	REGISTRATION MEMORY 4		01
LD208	WF30100R	LED (CHIP)	SML-012PTT86A GREEN	チ ッ プ L E D テー	REGISTRATION MEMORY 4		01
LD209	WF300900	LED (CHIP)	SML-512DW ORANGE	チ ッ プ L E D テー	REGISTRATION MEMORY 5		01
LD210	WF30100R	LED (CHIP)	SML-012PTT86A GREEN	チ ッ プ L E D テー	REGISTRATION MEMORY 5		01
LD211	WF300900	LED (CHIP)	SML-512DW ORANGE	チ ッ プ L E D テー	REGISTRATION MEMORY 6		01
LD212	WF30100R	LED (CHIP)	SML-012PTT86A GREEN	チ ッ プ L E D テー	REGISTRATION MEMORY 6		01
LD213	WF300900	LED (CHIP)	SML-512DW ORANGE	チ ッ プ L E D テー	REGISTRATION MEMORY 7		01
LD214	WF30100R	LED (CHIP)	SML-012PTT86A GREEN	チ ッ プ L E D テー	REGISTRATION MEMORY 7		01
LD215	WF300900	LED (CHIP)	SML-512DW ORANGE	チ ッ プ L E D テー	REGISTRATION MEMORY 8		01
LD216	WF30100R	LED (CHIP)	SML-012PTT86A GREEN	チ ッ プ L E D テー	REGISTRATION MEMORY 8		01
LD301	WF300900	LED (CHIP)	SML-512DW ORANGE	チ ッ プ L E D テー	ONE TOUCH 1		01
LD302	WF300900	LED (CHIP)	SML-512DW ORANGE	チ ッ プ L E D テー	ONE TOUCH 2		01
LD303	WF300900	LED (CHIP)	SML-512DW ORANGE	チ ッ プ L E D テー	ONE TOUCH 3		01
LD304	WF300900	LED (CHIP)	SML-512DW ORANGE	チ ッ プ L E D テー	ONE TOUCH 4		01
LD305	WF300900	LED (CHIP)	SML-512DW ORANGE	チ ッ プ L E D テー	LEFT		01
LD306	WF300900	LED (CHIP)	SML-512DW ORANGE	チ ッ プ L E D テー	DUAL		01
LD307	WF300900	LED (CHIP)	SML-512DW ORANGE	チ ッ プ L E D テー	HARMONY		01
LD308	WF300900	LED (CHIP)	SML-512DW ORANGE	チ ッ プ L E D テー	SUSTAIN		01
LD309	WF300900	LED (CHIP)	SML-512DW ORANGE	チ ッ プ L E D テー	TOUCH		01
LD310	WF300900	LED (CHIP)	SML-512DW ORANGE	チ ッ プ L E D テー	DSP		01
	V869530R	CIRCUIT BOARD	61L 16N2M C61 P2	シ ー ト 6 1 L	(V869520)(X2336B0)		
10	VQ769500	ADHESIVE TAPE W=15	W=15	マ ス キ ン グ テ ー プ			
CN04	VK02560R	CONNECTOR BASE PIN	52147 12P TE	ワ イ ヤ ー ト ラ ッ プ		3	01
CN05	VK025100	CONNECTOR BASE PIN	52147 7P TE	ワ イ ヤ ー ト ラ ッ プ		3	
D001	VB941200	DIODE	1SS133,1SS176 TE	ダイ オード		3	
-072	VB941200	DIODE	1SS133,1SS176 TE	ダイ オード		3	
	V869550R	CIRCUIT BOARD	61H 16N2M C61 P2	シ ー ト 6 1 H	(V869540)(X2335C0)		06
10	VQ769500	ADHESIVE TAPE W=15	W=15	マ ス キ ン グ テ ー プ			
CN01	VK02560R	CONNECTOR BASE PIN	52147 12P TE	ワ イ ヤ ー ト ラ ッ プ		3	01
CN02	VK024900	CONNECTOR BASE PIN	52147 5P TE	ワ イ ヤ ー ト ラ ッ プ		3	
CN03	VK02560R	CONNECTOR BASE PIN	52147 12P TE	ワ イ ヤ ー ト ラ ッ プ		3	01
D073	VB941200	DIODE	1SS133,1SS176 TE	ダイ オード		3	
-122	VB941200	DIODE	1SS133,1SS176 TE	ダイ オード		3	
	WH943500	AC ADAPTER	PA-301 E	A C ア ダ プ ター E			
	WH943400	AC ADAPTER	PA-301 U	A C ア ダ プ ター U,C			12
	WH943300	AC ADAPTER	PA-301 J	A C ア ダ プ ター J			
	WJ049600	AC ADAPTER	PA-301 CHN	A C ア ダ プ ター O			14
	WH943600	AC ADAPTER	PA-301 GBR	A C ア ダ プ ター B			14
	X0159A0R	SPEAKER(TWEETER)	3.0cm	ス ピ ー カ		2	

* : New Parts (新規部品)

12.0cm 8 ohm 10W

RANK : Japan only

CL

PSR-S550/PSR-S550B OVERALL CIRCUIT DIAGRAM 1/5 (DM 1/2)

CONTENTS

PSR-S550/PSR-S550B OVERALL CIRCUIT DIAGRAM

- 61H 4
- 61L 4
- AM 3
- DM 1/2 1
- DM 2/2 2
- ENC 3
- JACK 3
- PB 3
- MVR 3
- PNC 4
- PNL 5
- PNR 4
- PSW 3
- TW 3

DM 1/2

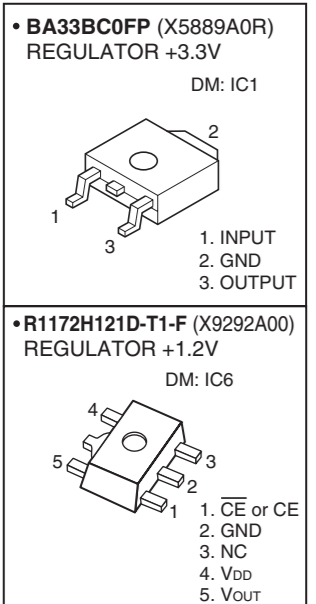
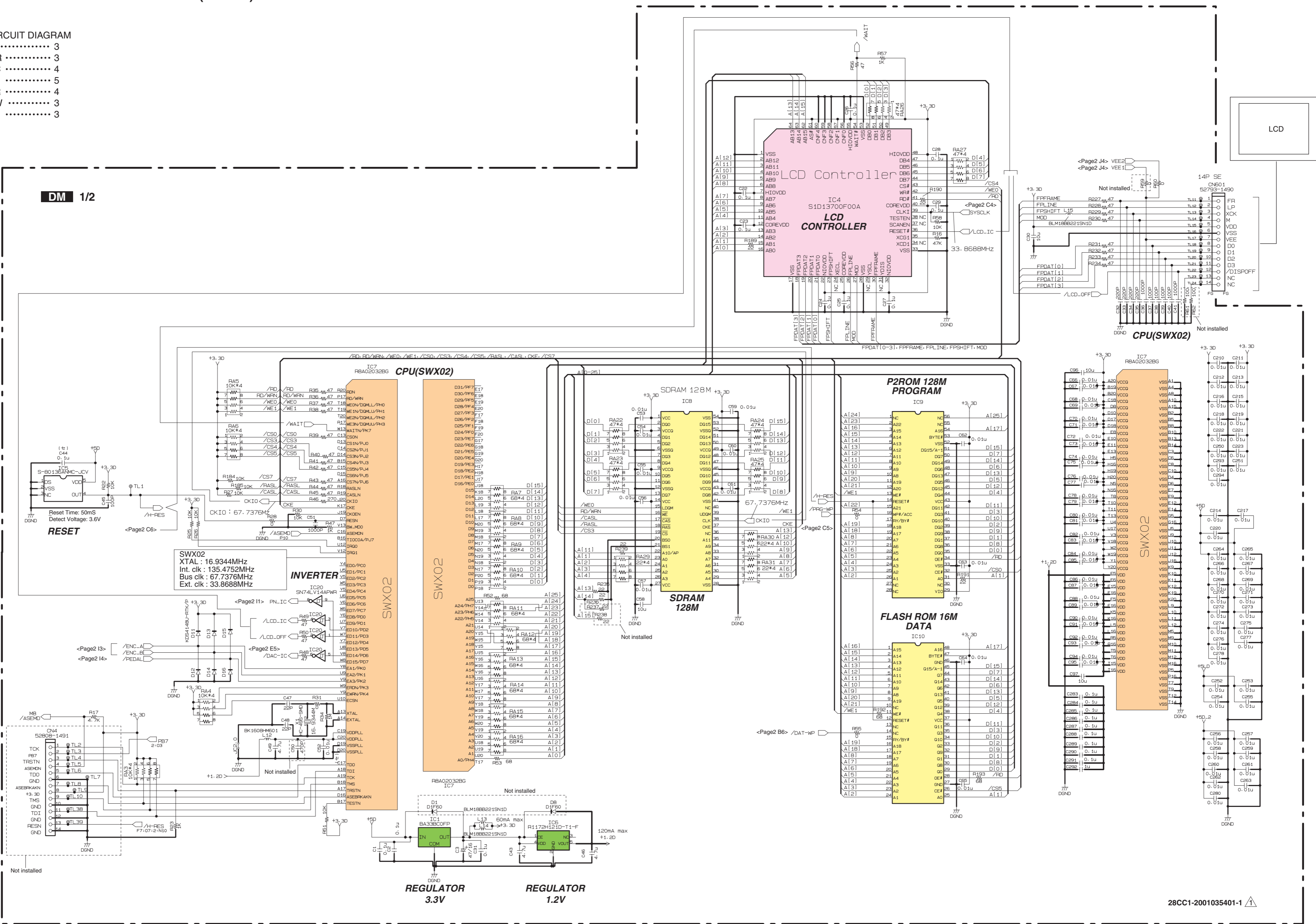

Notation for Circuit Diagrams

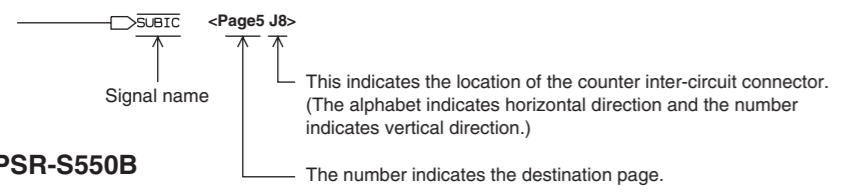

WARNING

Components having special characteristics are marked Δ and must be replaced with parts having specification equal to those originally installed.

Δ 印の部品は、安全を維持するために重要な部品です。交換する場合は、安全の為に必ず指定の部品を御使用ください。

⊕ : Ceramic Capacitor (セラミックコンデンサ)

Note: See parts list for details of circuit board component parts. 注: シートの部品詳細はパーツリストを御参照ください。

PSR-S550/PSR-S550B OVERALL CIRCUIT DIAGRAM 2/5 (DM 2/2)

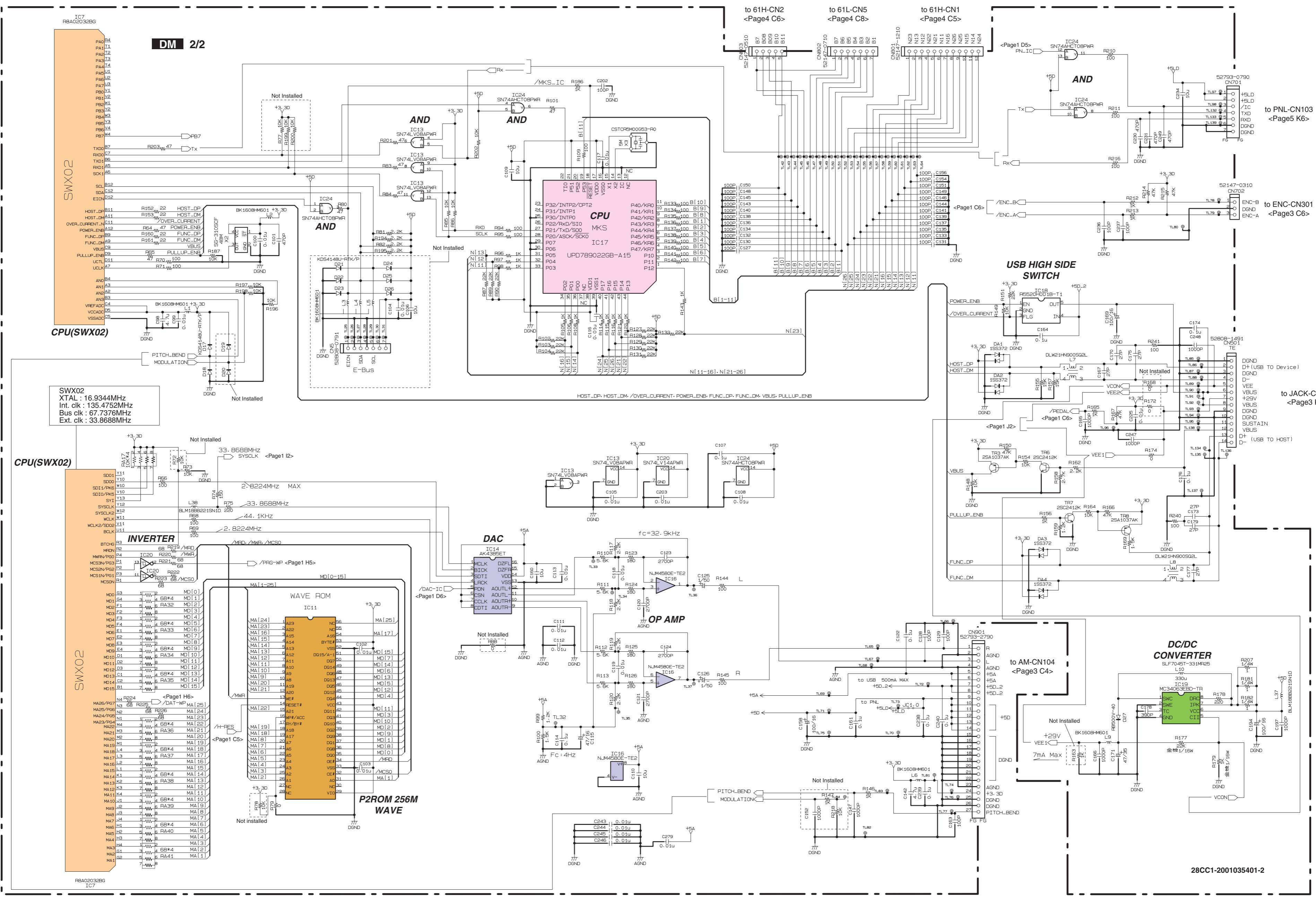

WARNING
 Components having special characteristics are marked Δ and must be replaced with parts having specification equal to those originally installed.
 Δ 印の部品は、安全を維持するために重要な部品です。
 交換する場合は、安全の為に必ず指定の部品を御使用ください。

\pm : Ceramic Capacitor (セラミックコンデンサー)
 \square : Metal Film Resistor (金属被膜抵抗)

Note: See parts list for details of circuit board component parts.
 注: シートの部品詳細はパーツリストを御参照ください。

PSR-S550/PSR-S550B OVERALL CIRCUIT DIAGRAM 3/5 (AM, JACK, ENC, MVR, PB, PSW, TW)

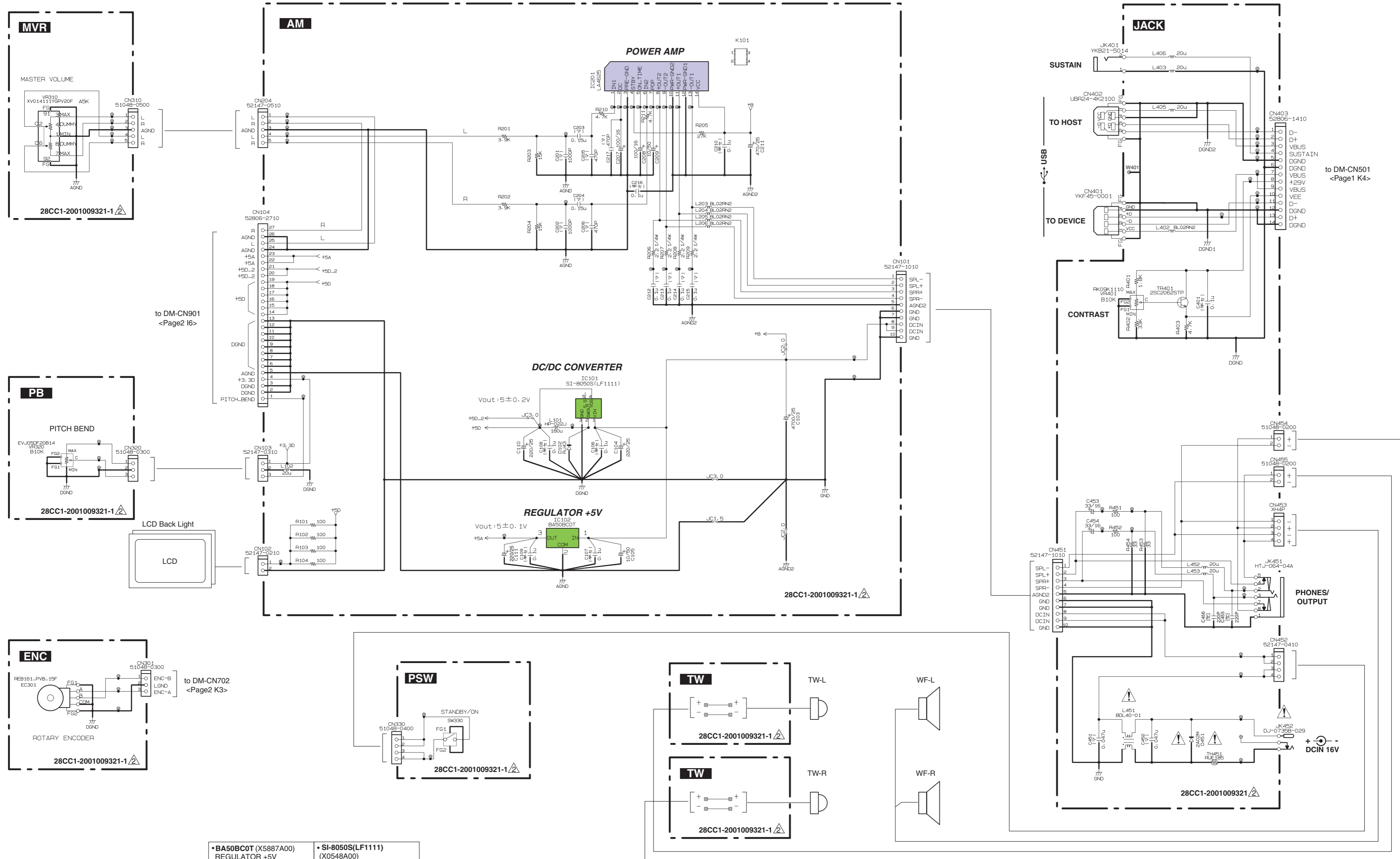

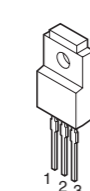
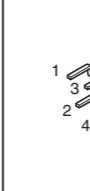
<p>• BA50BC0T (X5887A00) REGULATOR +5V AM: IC102</p>  <ol style="list-style-type: none"> INPUT OUTPUT GND 	<p>• SI-8050S (LF1111) DC-DC CONVERTER AM: IC101</p>  <ol style="list-style-type: none"> V in SW OUT GND V ss S.S
---	---

WARNING
 Components having special characteristics are marked Δ and must be replaced with parts having specification equal to those originally installed.
 Δ 印の部品は、安全を維持するために重要な部品です。交換する場合は、安全の為に必ず指定の部品を御使用ください。

(マ) : Mylar Capacitor (マイラーコンデンサー)
 (セ) : Ceramic Capacitor (セラミックコンデンサー)

Note: See parts list for details of circuit board component parts.
 注: シートの部品詳細はパーツリストを御参照ください。

PSR-S550/PSR-S550B OVERALL CIRCUIT DIAGRAM 4/5 (PNC, PNR, 61H, 61L)

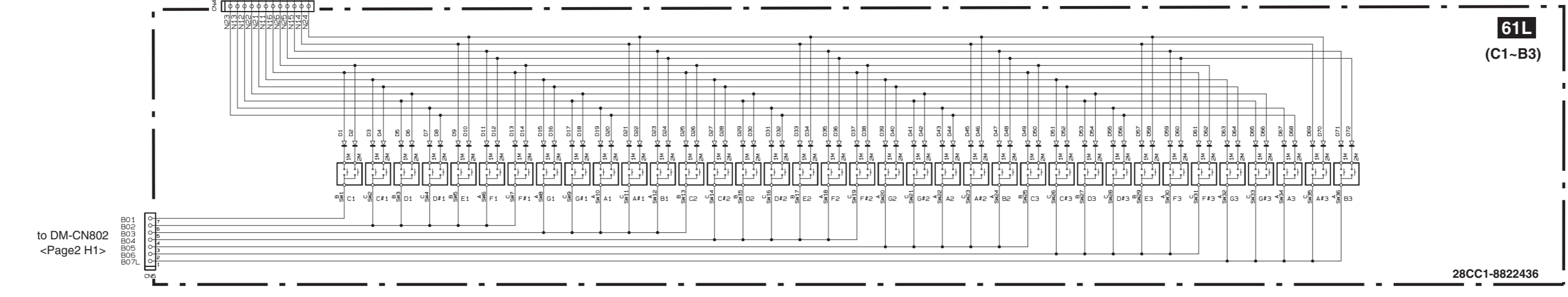
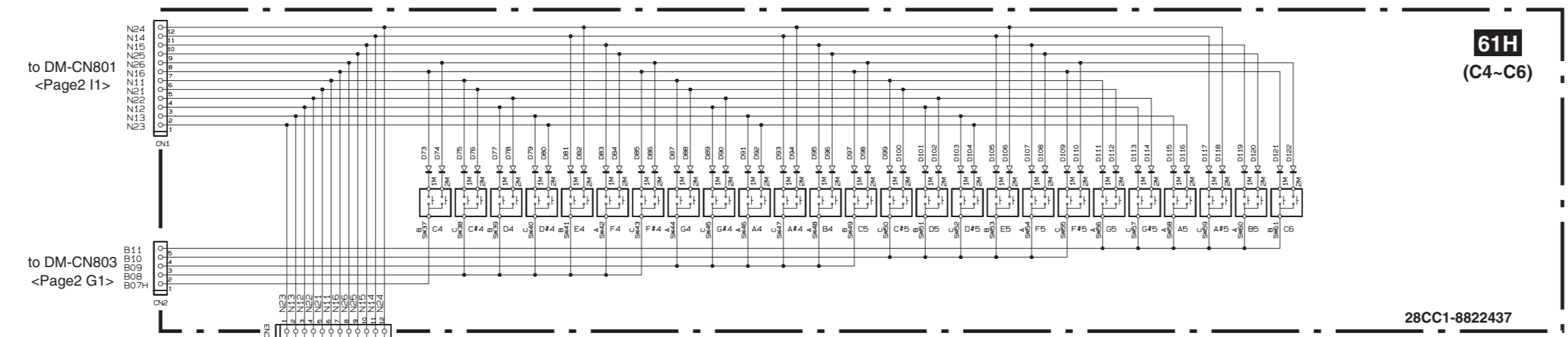
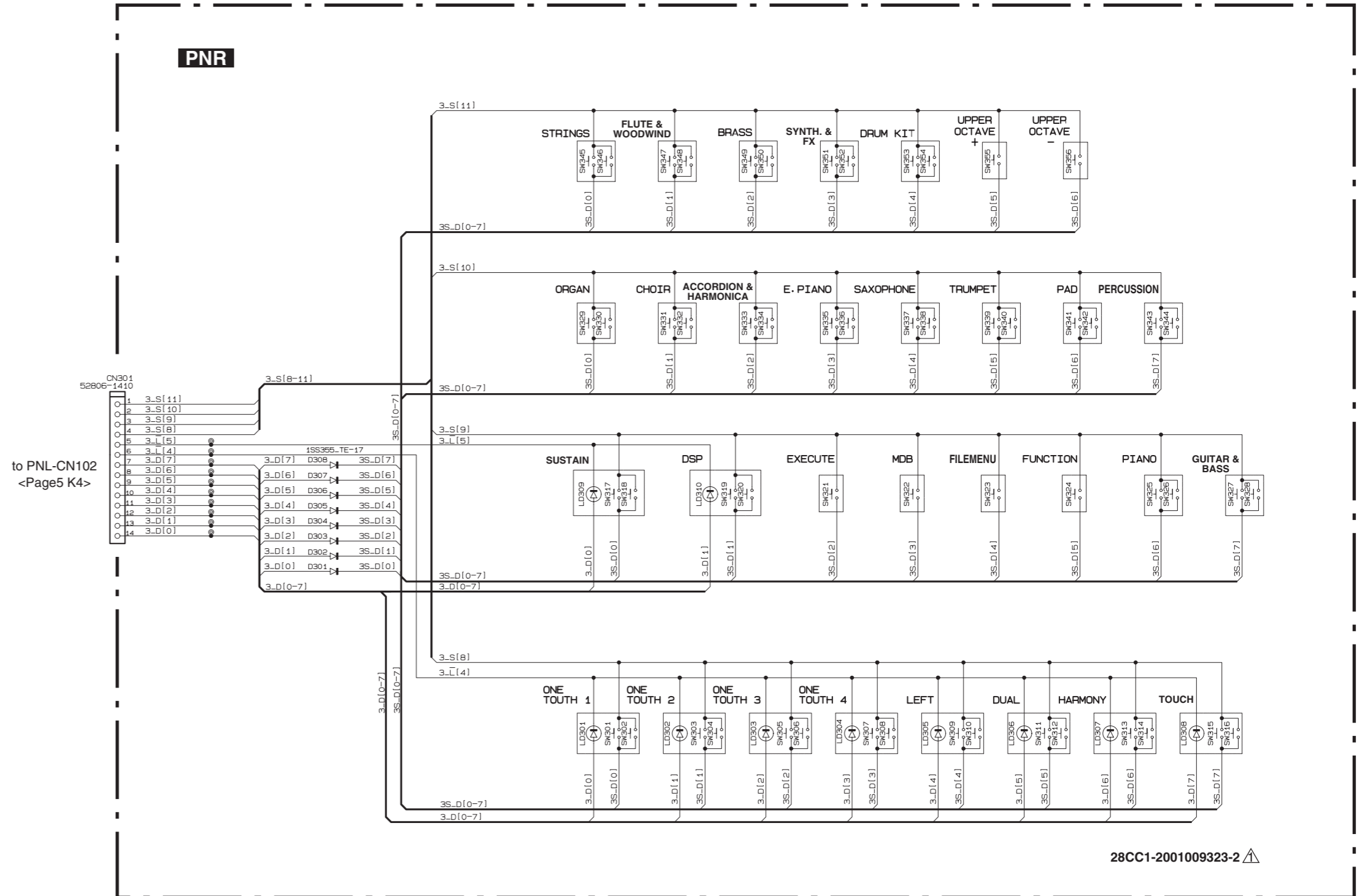
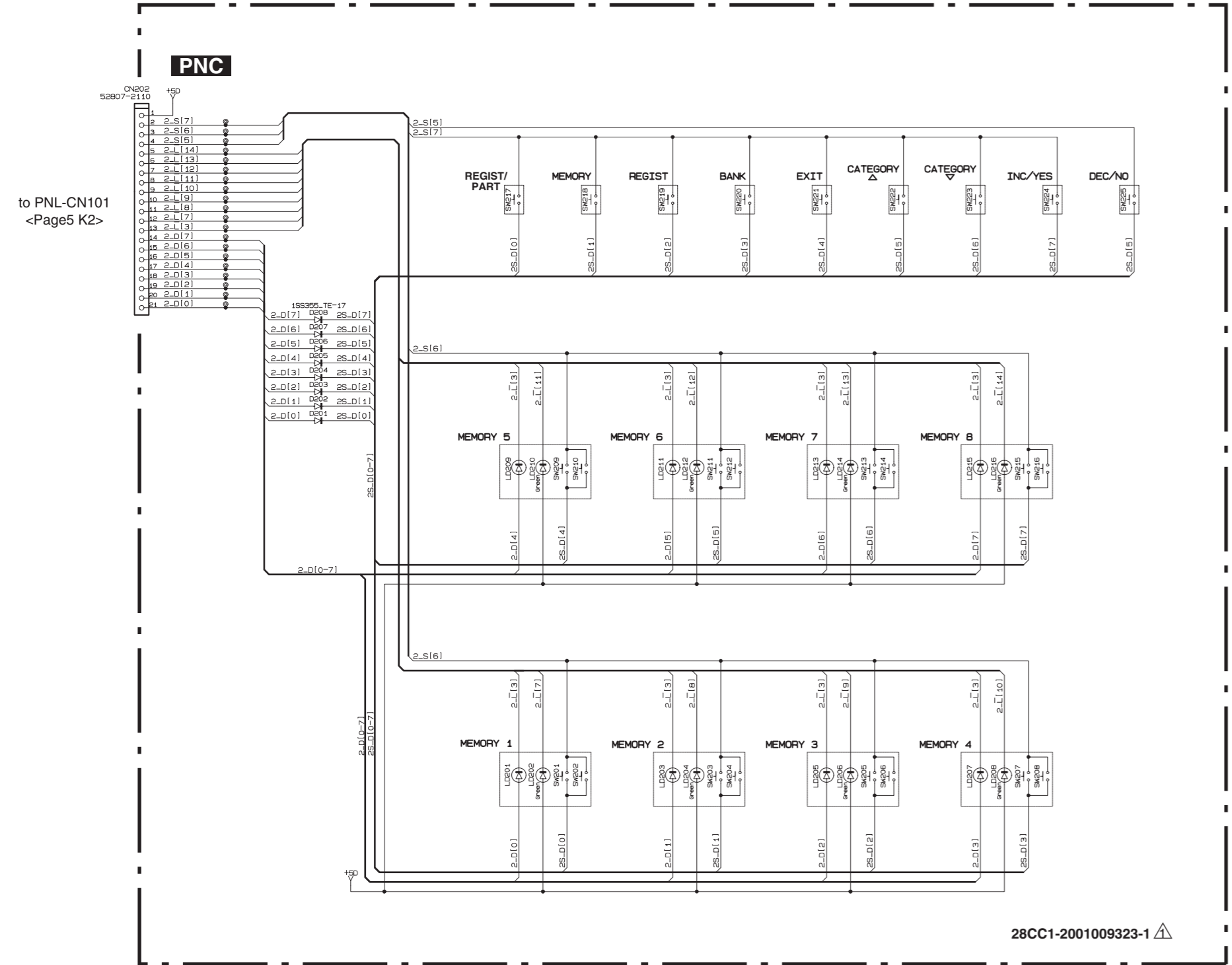

WARNING
 Components having special characteristics are marked Δ and must be replaced with parts having specification equal to those originally installed.
 Δ 印の部品は、安全を維持するために重要な部品です。
 交換する場合は、安全の為に必ず指定の部品を御使用ください。

Note: See parts list for details of circuit board component parts.
 注：シートの部品詳細はパーツリストを御参照ください。

PSR-S550/PSR-S550B OVERALL CIRCUIT DIAGRAM 5/5 (PNL)

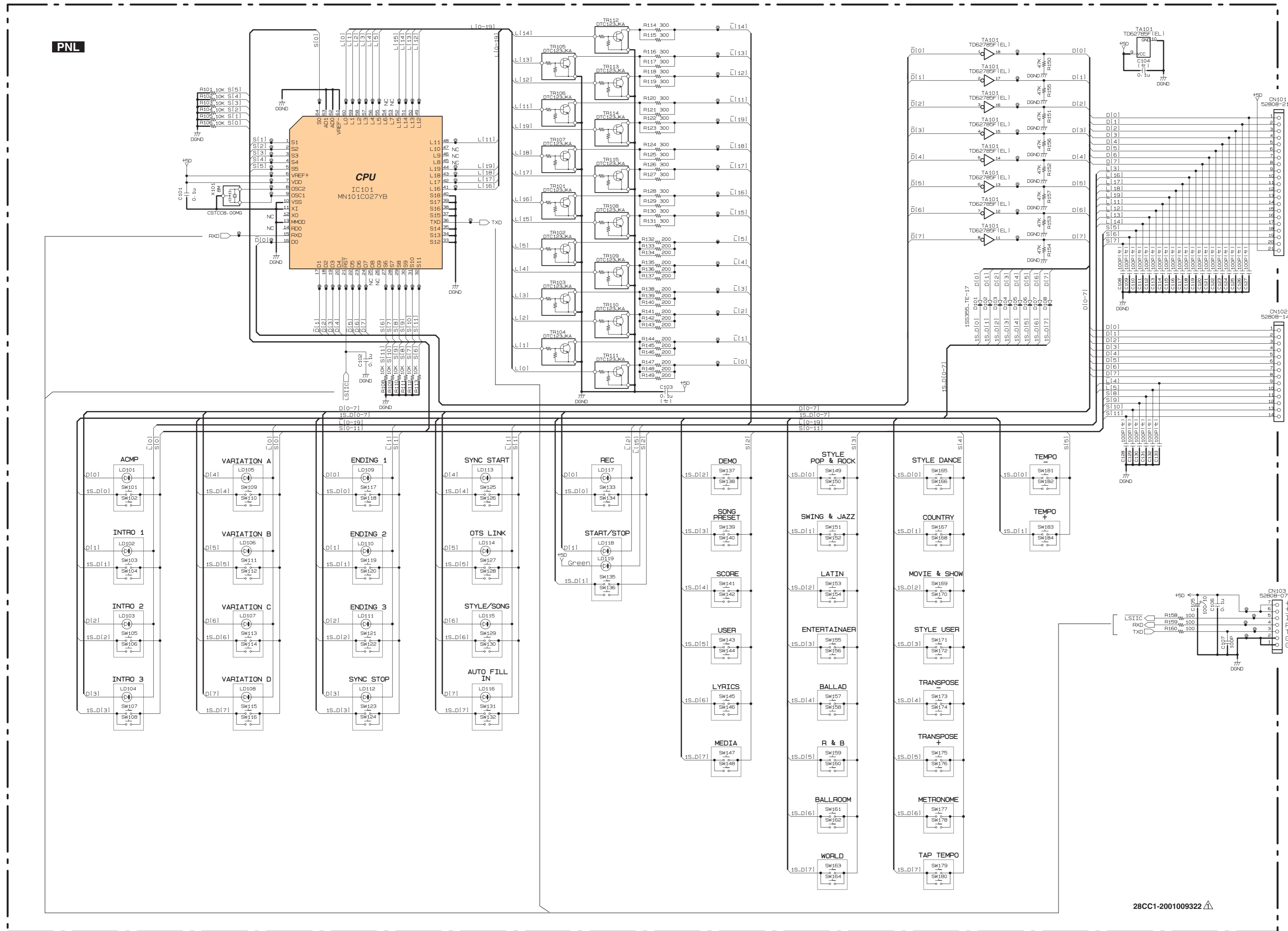

to PNC-CN202
<Page4 A2>

to PNR-CN301
<Page4 F3>

to DM-CN701
<Page2 K2>

28CC1-2001009322

WARNING
 Components having special characteristics are marked Δ and must be replaced with parts having specification equal to those originally installed.
 Δ 印の部品は、安全を維持するために重要な部品です。
 交換する場合は、安全の為に必ず指定の部品を御使用ください。

(セ) : Ceramic Capacitor (セラミックコンデンサー)

Note: See parts list for details of circuit board component parts.
注: シートの部品詳細はパーツリストを御参照ください。